

SLM336 Hardware Design Manual

Version Number: V1.02

Released date: 2023/02

IMPORTANT NOTICE

COPYRIGHT NOTICE

Copyright © MeiG Smart Technology Co., Ltd. All rights reserved.

All contents of this manual are exclusively owned by MeiG Smart Technology Co., Ltd (MeiG Smart for short), which is under the protection of Chinese laws and copyright laws in international conventions. Anyone shall not copy, spread, distribute, modify or use in other ways with its contents without the written authorization of MeiG Smart. Those who violated will be investigated by corresponding legal liability in accordance with the law.

NO GUARANTEE

MeiG Smart makes no representation or warranty, either express or implied, for any content in this document, and will not be liable for any specific merchantability and applicable or any indirect, particular and collateral damage.

CONFIDENTIALITY

All information contained here (including any attachments) is confidential. The recipient acknowledges the confidentiality of this document, and except for the specific purpose, this document shall not be disclosed to any third party.

DISCLAIMER

MeiG Smart will not take any responsibility for any property and health damage caused by the abnormal operation of customers. Please develop the product according to the technical specification and designing reference guide which defined in the product manual. MeiG Smart have the right to modify the document according to technical requirement with no announcement to the customer.

Revision History

NO	Version number	Time	Author	Reasons for revision
1	V1.00	2023-01	Hardware Department	Initial establishment
2	V1.01	2023-02	Hardware Department	modify some AT commands and delete some short message storage related content; Modify GSM characteristics
3	V1.02	2023-02	Hardware Department	Modify package description and sim card information

Content

1 Introduction.....	5
1.1 Safety Instruction	6
1.2 Documentation Purposes	7
1.3 Content.....	7
2 Product Overview.....	8
2.1 Basic Description	8
2.2 Main Performance	8
2.3 Functional Block Diagram.....	10
2.4 Evaluation Board.....	11
3 Application Interface.....	12
3.1 Basic Description	12
3.2 LCC Card Pin Definition.....	13
3.3 PIN Description	13
3.4 Power.....	23
3.4.1 Power Supply	23
3.4.2 Reduce Voltage Drop	23
3.4.3 Power Supply Reference Circuit.....	24
3.4.4 VDD_EXT Voltage Output	25
3.5 Switch Machine	25
3.5.1 PWRKEY Pin boot.....	25
3.5.2 Shutdown	27
3.6 Reset	27
3.6.1 Hardware Reset	27
3.6.2 AT Command Reset.....	28
3.7 USIM/SIM Port	28
3.8 USB Interface.....	31
3.8.1 USB Pin Description.....	31
3.8.2 USB Reference Circuit.....	32
3.9 Serial Port	33
3.10 Status Indication	35
3.11 Low Power Mode.....	36
3.11.1 Flight Mode.....	36
3.11.2 ULPS.....	37
3.12 ADC Mode	37
3.13 USB_BOOT Interface.....	37
3.14 AUDIO Interface.....	38
3.15 PCM Interface	38
3.16 I2C Interface	39
3.17 SPI Port.....	39
3.18 Function Multiplexing Interface.....	40
4 Antenna Interface.....	42
4.1 Antenna Interface	42
4.2 RF Reference Circuit.....	43
4.2.1 Antenna Connection Reference Design.....	43
4.2.2 RF Signal Line Layout.....	43
4.3 Antenna Installation.....	45
4.3.1 Antenna Requirements	45
4.3.2 RF output power.....	45
4.3.3 RF Frequency.....	46
4.3.4 Working Frequency	46

4.3.5 OTA Antenna Requirements 47

5 Electrical Characteristics 48

5.1 Limited Voltage Range..... 48

5.2 Ambient Temperature Range..... 48

5.3 Electrical Characteristics of Interface Working State 49

5.4 Power Consumption Range 49

6 Mechanical Characteristics 73

6.1 Module Dimension..... 73

6.2 Recommended Package 74

6.3 Module Top View 74

6.4 Module Bottom View 75

7 Storage and Production..... 76

7.1 Storage..... 76

7.2 Manufacturing Welding 77

8 Appendix A Reference and Term Abbreviation 78

8.1 Reference 78

8.2 Term Abbreviation 78

MeiG Confidential

1 Introduction

This document defines the SLM336 module and the air interface and hardware interface between module and customer application.

This document can help customers quickly understand SLM336 module interface specification electrical characteristics mechanical specifications and related product information. With the help of this document, combined with our application manual and user instructions, customers can quickly apply SLM336 module to wireless applications.

SLM336 is a wide band wireless terminal product applicable to TDD-LTE/FDD-LTE/GSM multiple network standards and multiple frequency bands.

Supported access rates supported by SLM336

- GSM: 85.6kbps/85.6kbps;
- TDD-LTE: 8Mbps/2Mbps;
- FDD-LTE:10Mbps/5Mbps;

Except wireless data access, SLM336 can be widely used in M2M field, such as OTT, CPE, router, data card, tablet computer, security and industrial PDA.

1.1 Safety Instruction

By following the following safety principles, you can ensure personal safety and help protect products and the working environment from potential damage:

	<p>Driving safety first! When you drive, do not use the handheld mobile terminal device unless it has hands-free function. Please stop and call again!</p>
	<p>Please turn off the mobile terminal before boarding. The wireless function of the mobile terminal shall not be turned on the aircraft to prevent interference with the aircraft communication system. Ignoring this prompt may lead to flight safety and even violate the law.</p>
	<p>In hospitals or health care places, pay attention to whether there are restrictions on the use of mobile terminal equipment. RF interference will lead to abnormal operation of medical equipment, so it may be necessary to turn off the mobile terminal equipment.</p>
	<p>The mobile terminal device cannot be effectively connected under any circumstances. Where there is no phone charge or SIM is invalid in the mobile device. When you encounter the above situations in an emergency, please remember to make an emergency call and ensure that your device is turned on and in an area with sufficient signal strength.</p>
	<p>Your mobile terminal device receives and transmits radio frequency signals when it is turned on. Radio frequency interference may occur when near televisions, radios, computers or other electronic equipment.</p>
	<p>Keep your mobile device away from flammable gases. When you are close to gas stations, oil depots, chemical plants or explosive workplaces, please turn off the mobile terminal equipment. Operating electronic equipment in any place with potential explosion hazard has potential safety hazards.</p>

1.2 Documentation Purposes

This article elaborates the basic functions, main features, hardware interface and its use method, structural characteristics, power consumption index and electrical characteristics of SLM336 wireless module in detail, and guides users to apply SLM336 module to various application terminals.

1.3 Content

This document is divided into the following parts:

- Chapter 1, mainly introduces security instructions, document purpose, revision history, etc.
- Chapter 2 describes the basic functions and main features of THE SLM336 wireless module.
- Chapter 3 describes in detail the functional features and usage of each SLM336 hardware interface
- Chapter 4, antenna interface related content and matters needing attention;
- Chapter 5, electrical characteristics of SLM336 are described in detail;
- Chapter 6, the structural features and considerations of SLM336 are described in detail;
- Chapter 7 describes in detail the storage and production considerations for SLM336;
- Chapter 8, Appendix A Reference documents and term abbreviations;
- Chapter 9, Appendix B GPRS coding Scheme

2 Product Overview

2.1 Basic Description

SLM336 is a wireless communication module that supports GSM /TDD-LTE/FDD-LTE, and can provide voice (PCM) and analog voice SMS for customers.

Table 1 SLM336 module support frequency band

Internet	SLM336
FDD-LTE	B1/B3/B5/B7/B8/B20/B28
GSM	850/900/1800/1900

SLM336 adopts an advanced highly integrated design scheme with RF and baseband onto PCB to realize radio transmission, receiving, baseband signal and audio signal processing. It is a single-sided layout, module size: 23.6*19.9* 2.45 mm, which can be widely used in M2M such as OTT,CPE, routers, data CARDS, data card, tablet, security and industrial-grade PDA, etc.

2.2 Main Performance

The following table shows the performance of the SLM336 module.

Table 2 Lists the main features of the module

Parameters	Explain
Power supply	<ul style="list-style-type: none"> ● VBAT Supply voltage range: 3.5V~4.2V ● Typical supply voltage: 3.8V
Transmitted power	<ul style="list-style-type: none"> ● Class 3 (23dBm±2dB) for FDD-LTE bands ● Class 4 (33dBm±2dB) for GSM900 PCL5 ● Class 4 (33dBm±2dB) for GSM850 PCL5 ● Class 1 (30dBm±2dB) for DCS1800 PCL0 ● Class 1 (30dBm±2dB) for PCS1900 PCL0
LTE character	<ul style="list-style-type: none"> ● The maximum support CAT1 ● Support 1.4 ~ 20 MHZ radio frequency bandwidth ● FDD: The maximum UL rate is 5Mbps, and the maximum DL rate is 10Mbps
GSM character	GPRS: <ul style="list-style-type: none"> ● Support GPRS multi-slot class 12 (12 by default) ● Encoding format: CS-1/CS-2/CS-3 and CS-4

	<ul style="list-style-type: none"> ● Maximum 4 RX slots per frame
Network protocol characteristics	<ul style="list-style-type: none"> ● TCP/IP/UDP/HTTP(S)/MQTT/FTP/SSL/OneNet
Short message service (SMS)	<ul style="list-style-type: none"> ● Text and PDU mode ● point-to-point MO and MT ● Short message storage ● Cell broadcast
USIM port	<ul style="list-style-type: none"> ● Support USIM/SIM: 1.8V & 3V
Audio fidelity	<ul style="list-style-type: none"> ● Support 2 analog audio interfaces: 1 analog audio input and 1 analog audio output ● GSM: HR/FR/EFR/AMR/AMR-WB ● Support echo cancellation and noise reduction
PCM port	<ul style="list-style-type: none"> ● For audio use, external CODEC chip is needed
USB port	<ul style="list-style-type: none"> ● Support USB2.0(slave mode only), the maximum data transmission rate is 480 Mbps ● To the AT command, data transmission, software debugging and software upgrades ● USB driver: Support Windows7, Windows 8/8.1, Windows10
Serial port	<p>MAIN_UART/ AUX_UART:</p> <ul style="list-style-type: none"> ● To AT commands and data transmission ● Baud rate is default 115200bps ● MAIN_UART support RTS and CTS hardware fluid control, AUX_UART dose not support RTS and CTS hardware fluid control <p>DBGU:</p> <ul style="list-style-type: none"> ● For debugging, log output ● Baud rate is default115200bps
AT order	<ul style="list-style-type: none"> ● Comply with 3GPP TS 27.007, 27.005, and has a new MeiG AT command
Network indicator	<ul style="list-style-type: none"> ● NET_STATUS pin indicate the state of the network
Antenna port	<ul style="list-style-type: none"> ● Main antenna interface (ANT_MAIN) ● Bluetooth /Wi-Fi Scan antenna interface (ANT_BT/WIFI_SCAN) 50 ω characteristic impedance
Physical property	<ul style="list-style-type: none"> ● Size: 23.6×19.9×2.45mm ● Weight: 2.4 g
Temperature Range	<ul style="list-style-type: none"> ● Normal operating temperature: -30℃ ~+75℃ ● Extended operating temperature: -40℃ ~+85℃ ● Storage temperature:-40℃ ~+90℃
Software upgrading	<ul style="list-style-type: none"> ● USB port
RoHS	<ul style="list-style-type: none"> ● All devices comply fully with EU RoHS standards
Port	<ul style="list-style-type: none"> ● 126Pin ,LGA port
LCC functional interface	<ul style="list-style-type: none"> ● power port ● USB2.0 High-Speed port ● UART port ● USIM/SIM port (support 3V、 1.8V, SIM2 is under

development)

- MIC input interface
- SPK interface(As a speaker, an external power amplifier is required)
- Hardware reset interface
- Pilot light interface
- Flight mode control interface
- ADC port
- I2C port
- SPI port
- USB_BOOT port

2.3 Functional Block Diagram

The following is the block diagram of SLM336, illustrating its main functions.

- PMU
- BBU
- Internal memory
- The RF part
- Peripheral interface

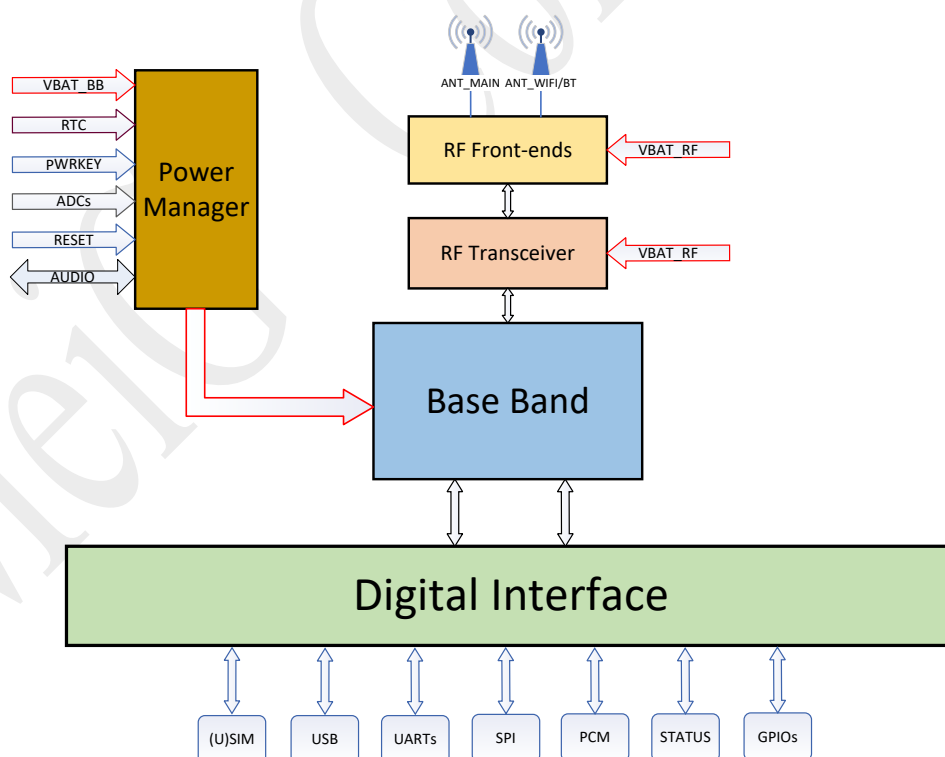

FIG. 1 Functional block diagram

2.4 Evaluation Board

For testing and use of SLM336, MeiG provides a set of evaluation board, including USB cables, antennas, and other peripherals.

Please refer to the “SLM336_USB_ZB User Manual” for the specific usage of the evaluation board.

MeiG Confidential

3 Application Interface

3.1 Basic Description

SLM336 adopts 126 pin LGA, providing the following functional interfaces:

- Power supply
- USB2.0 High-Speed interface
- UART port
- USIM/SIM port (support 3V, 1.8V, The hot plug function of sim2 is under development.)
- MIC input interface
- SPK interface(As a speaker, an external power amplifier is required)
- Hardware reset interface
- Pilot light interface
- Flight mode control interface
- ADC port
- I2C port
- SPI port
- USB_BOOT port

3.2 LCC Card Pin Definition

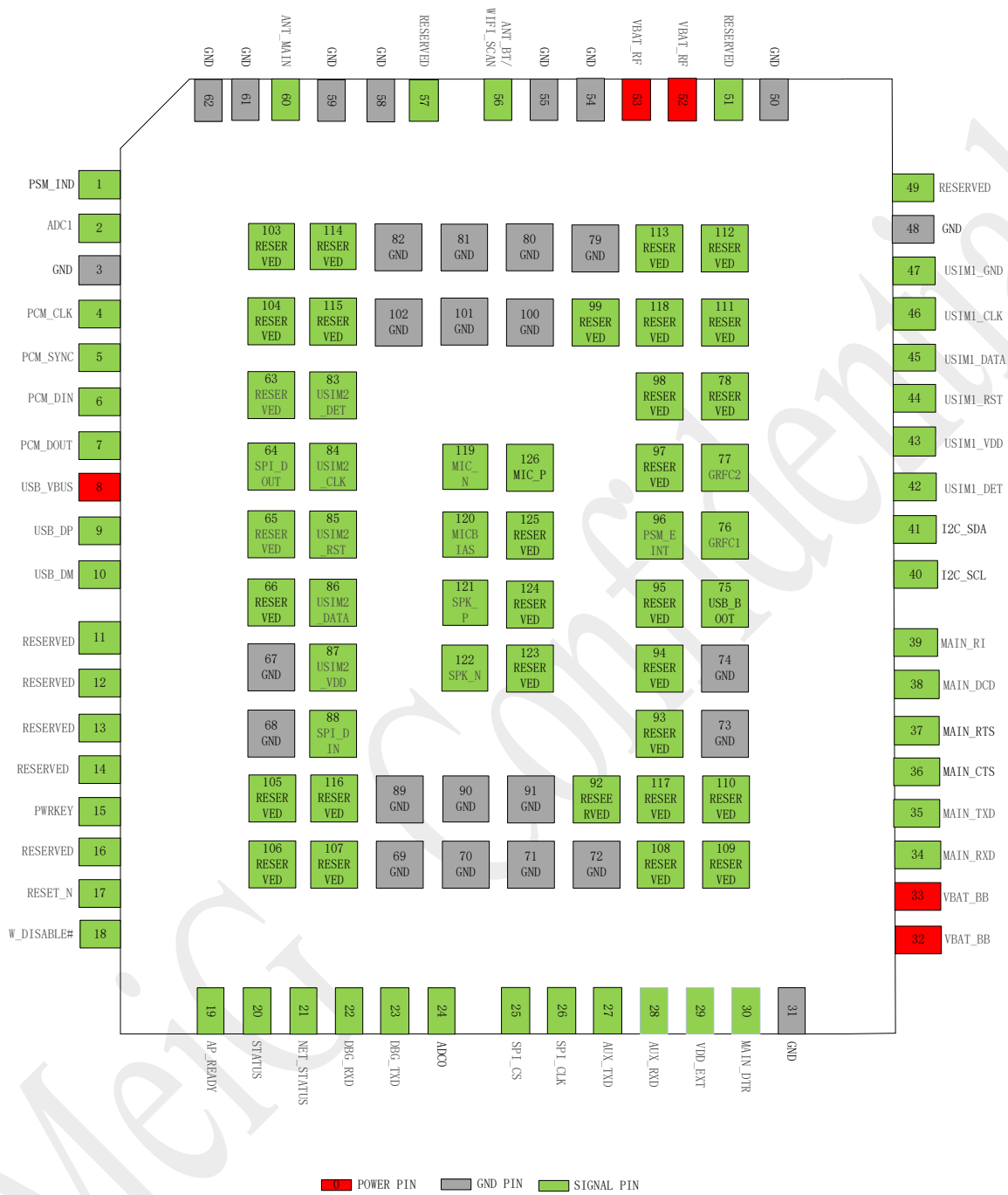

FIG. 2 Pin diagram of module sequence number

3.3 PIN Description

The following table shows the definition of each pin in the SLM336 module.

Table 3 IO parameter definitions

Type	Description
IO	Input/Output
DI	Digital input signal.
DO	Digital output signal.
OD	Open drain output signal.
AI	Analog input
BOT	Bidirectional open drain output signal
PI	Power input
PO	Power output
G	GND

Table 4 Pin description

Pin Number	Pin Name	I/O	Electrical level	Description	Remark
1	PSM_IND	DO	VOLnom=0V VOHnom=1.8V	Enter PSM mode indication	Pull this pin high externally to make the module exit PSM mode
2	ADC1	AI		General ADC interface Voltage range: 0.1V~VBAT Leave empty if not used	
3	GND	G		GND	

4	PCM_CLK	DI	VILnom=0V VIHnom=1.8V	PCM clock signal Leave empty if not used	Only slave mode is supported
5	PCM_SYNC	DI	VILnom=0V VIHnom=1.8V	PCM frame signal synchronization Leave empty if not used	Only slave mode is supported
6	PCM_DIN	DI	VILnom=0V VIHnom=1.8V	PCM data input signal Leave empty if not used	Only slave mode is supported
7	PCM_DOUT	DO	VOLnom=0V VOHnom=1.8V	PCM data output signal Leave empty if not used	Only slave mode is supported
8	USB_VBUS	AI	Vnorm=5.0V	USB Insertion signal Leave empty if not used	
9	USB_DP	AIO		USB Differential data (+) Leave empty if not used	
10	USB_DM	AIO		USB Differential data (-) Leave empty if not used	
11	RESERVED			RESERVED	
12	RESERVED			RESERVED	
13	RESERVED			RESERVED	
14	RESERVED			RESERVED	
15	PWRKEY	DI	VILnom=0V VIHnom=VBAT	Power on/off Active at low level	

16	RESERVED			RESERVED	
17	RESET_N	DI	VILnom=0V VIHnom=VBAT	Module reset Active at low level	
18	W_DISABLE#	DI	VILnom=0V VIHnom=1.8V	Flight mode control Leave empty if not used	
19	AP_READY	DI	VILnom=0V VIHnom=1.8V	Application processor sleep state detection Leave empty if not used	
20	STATUS	DO	VOLnom=0V VOHnom=1.8V	Running status indication Leave empty if not used	
21	NET_STATUS	DO	VOLnom=0V VOHnom=1.8V	Network status indication Leave empty if not used	
22	DBG_RXD	DI	VILnom=0V VIHnom=1.8V	DBG UART RXD Leave empty if not used.	
23	DBG_TXD	DO	VOLnom=0V VOHnom=1.8V	DBG UART TXD Leave empty if not used	
24	ADC0	AI		General ADC interface Voltage range: 0.1V~VBAT Leave empty if not used	
25	SPI_CS	DO	VOLnom=0V VOHnom=1.8V	SPI chip selection Leave empty if not used	
26	SPI_CLK	DO	VOLnom=0V VOHnom=1.8V	SPI CLK Leave empty if not used	

27	AUX_TXD	DO	VOLnom=0V VOHnom=1.8V	AUX_UART TX Leave empty if not used
28	AUX_RXD	DI	VILnom=0V VIHnom=1.8V	AUX_UART RX Leave empty if not used
29	VDD_EXT	PO	1.8V	Digital level, 1.8V output, 50mA load capacity Leave empty if not used
30	MAIN_DTR	DI	VILnom=0V VIHnom=1.8V	The main serial data terminal is ready Leave empty if not used
31	GND	G		GND
32	VBAT_BB	PI	Vmax=4.2 Vmin=3.5V Vnorm=3.8V	Module BB power
33	VBAT_BB	PI	Vmax=4.2 Vmin=3.5V Vnorm=3.8V	Module BB power
34	MAIN_RXD	DI	VILnom=0V VIHnom=1.8V	Main UART RX Leave empty if not used
35	MAIN_TXD	DO	VOLnom=0V VOHnom=1.8V	Main UART TX Leave empty if not used
36	MAIN_CTS	DO	VOLnom=0V VOHnom=1.8V	Main UART clear send Leave empty if not used
37	MAIN_RTS	DI	VILnom=0V VIHnom=1.8V	Main UART Request to send data Leave empty if not used

38	MAIN_DCD	DO	VOLnom=0V VOHnom=1.8V	Main UART output carrier detection Leave empty if not used	
39	MAIN_RI	DI	VILnom=0V VIHnom=1.8V	Main serial port output ringing prompt Leave empty if not used	
40	I2C_SCL	OD	VOLnom=0V VOHnom=1.8V	I2C serial clock Leave empty if not used	When in use, it needs to be externally pulled up to 1.8V. If the external interface is used to connect the CODEC, other peripherals cannot be connected.
41	I2C_SDA	OD	VOLnom=0V VOHnom=1.8V	I2C serial data Leave empty if not used	
42	USIM1_DET	DI	VILnom=0V VIHnom=1.8V	(U)SIM1 Hot swap detection signal the software turns off the detection function by default Leave empty if not used	
43	USIM1_VDD	PO	1.8V/3.0V	(U)SIM1 Power	
44	USIM1_RST	DO	1.8V/3.0V	(U)SIM1 reset signal	
45	USIM1_DATA	DIO	1.8V/3.0V	(U)SIM1 data signal	
46	USIM1_CLK	DO	1.8V/3.0V	(U)SIM1 clock signa	

47	USIM1_GND	G		(U)SIM1 GND	
48	GND	G		GND	
49	RESERVED			RESERVED	
50	GND	G		GND	
51	RESERVED			RESERVED	
52	VBAT_RF	PI	Vmax=4.2 Vmin=3.5V Vnorm=3.8V	Module RF power	
53	VBAT_RF	PI	Vmax=4.2 Vmin=3.5V Vnorm=3.8V	Module RF power	
54	GND	G		GND	
55	GND	G		GND	
56	ANT_BT/WIFI_SCAN	AIO	VILnom=0V VIHnom=1.8V	Bluetooth and Wi-Fi Scan Common antenna interface Leave empty if not used	cannot use Bluetooth and Wi-Fi Scan at the same time
57	RESERVED			RESERVED	

58	GND	G		GND	
59	GND	G		GND	
60	ANT_MAIN	AIO		Main antenna interface	
61	GND	G		GND	
62	GND	G		GND	
63	RESERVED			RESERVED	
64	SPI_DOUT	DO	VOLnom=0V VOHnom=1.8V	SPI Main mode output Leave empty if not used	Only main mode is supported
65	RESERVED			RESERVED	
66	RESERVED			RESERVED	
67~74	GND	G		GND	
75	USB_BOOT	DI	VILnom=0V VIHnom=1.8V	Emergency download mode control	Do not pull up before starting the module.
76	GRFC1	DO	VOLnom=0V VOHnom=1.8V	Universal radio frequency control 1 Leave empty if not used	

77	GRFC2	DO	VOLnom=0V VOHnom=1.8V	Universal radio frequency control 2 Leave empty if not used	
78	RESERVED			RESERVED	
79-82	GND	G		GND	
83	USIM2_DET*	DI	VILnom=0V VIHnom=1.8V	(U)SIM2Hot swap detection signal the software turns off the detection function by default Leave empty if not used	
84	USIM2_CLK	DO	1.8V/3.0V	(U)SIM2 clock signal	
85	USIM2_RST	DO	1.8V/3.0V	(U)SIM2 reset signal	
86	USIM2_DATA	DIO	1.8V/3.0V	(U)SIM2 data signal	
87	USIM2_VDD	PO	1.8V/3.0V	(U)SIM2 Power	
88	SPI_DIN	DI	VILnom=0V VIHnom=1.8V	SPI Main mode input Leave empty if not used	Only main mode is supported
89-91	GND	G		GND	
92-95	RESERVED			RESERVED	

96	PSM_EINT	DI	VILnom=0V VIHnom=1.8V	PSM Interrupt pin	Pull external high level to exit PSM
97~99	RESERVED			RESERVED	
100~102	GND	G		GND	
103~118	RESERVED			RESERVED	
119	MIC_N	AI		Microphone input channel (-)	
120	MICBIAS	PO	Vo=2.2~3.0V	Microphone bias voltage output	
121	SPK_P	AO		Analog audio differential output channel (+)	
122	SPK_N	AO		Analog audio differential output channel (-)	
123~125	RESERVED			RESERVED	
126	MIC_P	AI		Microphone input channel (+)	

Remark:

1. * means that the function is under development;
2. The above interface functions are not supported at the same time, some pins are multiplexed functions, please pay attention when selecting.
3. SLM336 pin multiplexing is presented in the document "SLM336_GPIO Function Multiplexing"

3.4 Power

Table 5 Description of SLM336 module power interface

Pin Name	I/O	Pin	Description
VBAT_BB	PI	32, 33	Module BB power supply, 3.5~4.2V, typical value 3.8
VBAT_RF	PI	52, 53	Module RF power supply, 3.5~4.2V, typical value 3.8
VDD_EXT	PO	29	Voltage output, 1.8V, 50mA loading capacity
GND	G	3,31,48,50,54,55,58,59,61,62,67~74,79~82,89~91,100~102	GND

3.4.1 Power Supply

SLM336 is supplied power through VBAT pin. The power design recommendation is shown in Figure 3

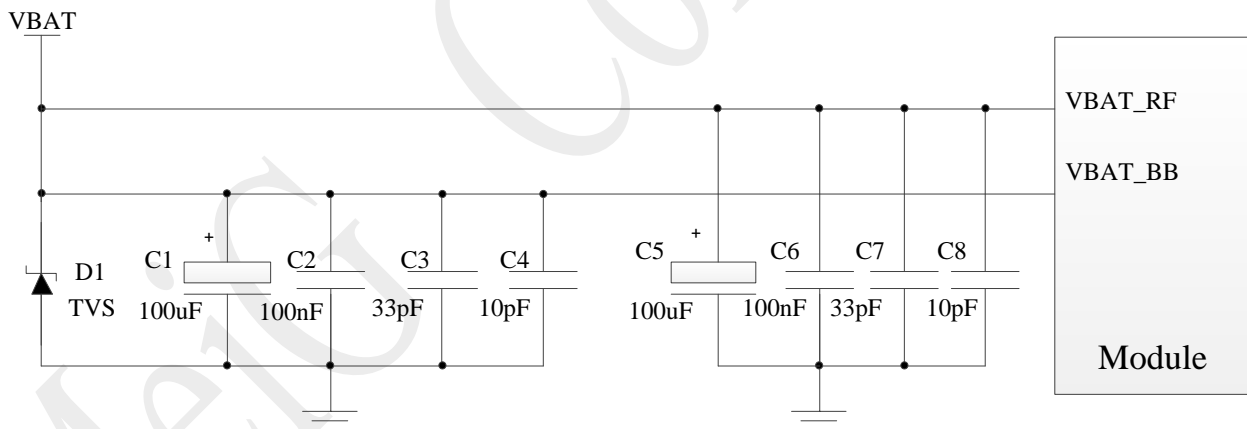

FIG. 3 Module power supply circuit

Remarks: The VBAT power supply needs star-shaped wiring to VBAT_BB and VBAT_RF, and the width of VBAT_RF wiring should be no less than 2.5mm. VBAT in subsequent documents includes VBAT_BB and VBAT_RF.

3.4.2 Reduce Voltage Drop

SLM336 power supply range of 3.5 V ~ 4.2 V. During data transmission or calls, instantaneous high-power transmission will form a current peak value of up to 2A, which will cause large ripples in VBAT. The module will reboot or shut down. In order to ensure normal operation, the power supply must

have sufficient power supply capacity, and the input voltage should not be lower than 3.5V.

Figure 4 below shows the voltage sag during burst transmission under 2G network, 4Figure 4 below shows the voltage sag during burst transmission under 2G network

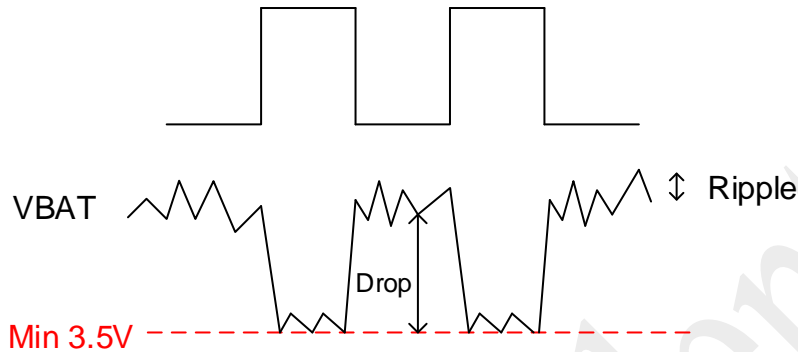

FIG. 4 Burst transmission power requirements

To reduce voltage drop, a 100uF filter capacitor with low ESR is required. MLCC has the best ESR. It is recommended to add 3 ceramic capacitors (100nF, 33pF, 10pF) to VBAT_BB and VBAT_RF pins, and the capacitors should be placed close to VBAT pins. At the same time, in order to ensure better power supply performance, a TVS tube is added near the input end of the module VBAT to improve the module's electrostatic bearing capacity. When the external power supply is connected to the module, VBAT_BB and VBAT_RF need to adopt star wiring. VBAT_BB wire width shall not be less than 2mm, and VBAT_RF wire width shall not be less than 2.5mm. In principle, the longer the line in VBAT, the wider the line.

3.4.3 Power Supply Reference Circuit

The design of the module power supply is very important, because the performance of the module depends largely on the power supply. The SLM336 must select a power source that provides at least 2A current capability. If the voltage difference between the input voltage and the module supply voltage is not very large, it is recommended to choose LDO as the supply. If there is a large voltage difference between the input and output voltages, DCDC is recommended as the power supply for the module.

The figure below is the reference design of + 5V power supply circuit. The LDO of Micrel company is used in the design, and the model is MIC29302WU. The load current is 3A and the output voltage is 3.9V.

Note: that MIC29302WU has the requirement of minimum load current $\geq 10\text{mA}$:

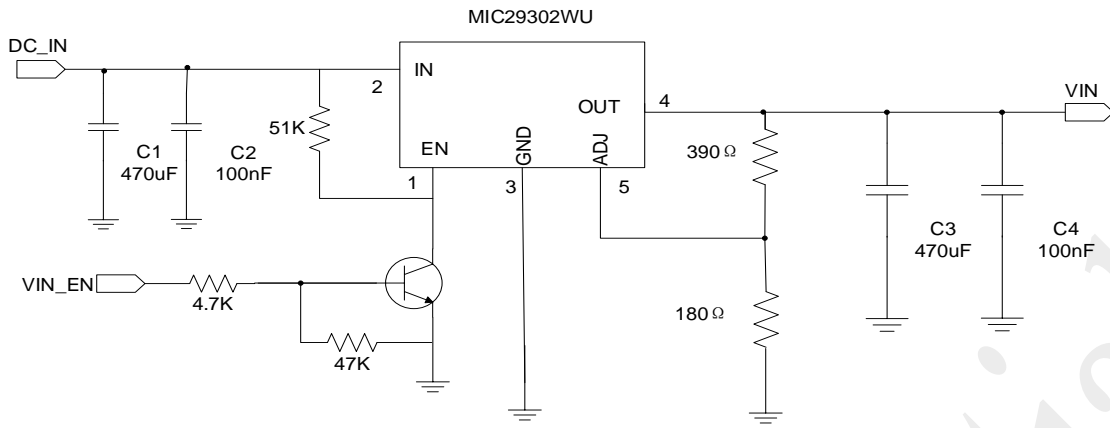

FIG. 5 Reference design for power supply input

3.4.4 VDD_EXT Voltage Output

When SLM336 normally boot, the voltage of output Pin29 is 1.8v as well as current load is 50mA. This output voltage can be used as an external pull-up source, such as a level reference, and the Pin status can be detected whether the module power on or not.

Table 6 Description of SLM336 module 1.8V voltage output interface

Pin Name	I/O	Pin	Description
VDD_EXT(VDD_1V8)	PO	29	1.8V voltage output

3.5 Switch Machine

3.5.1 PWRKEY Pin boot

Table 7 Description of SLM336 module 1.8V voltage output interface

Pin Name	I/O	Pin	Description
PWRKEY	DI	15	power on/off

When SLM336 stays at shutdown mode, the module can be waked up through pulling down the PWRKEY for at least 2s. It is recommended to use an open set drive circuit to control PWRKEY pins. The reference circuit shows following:

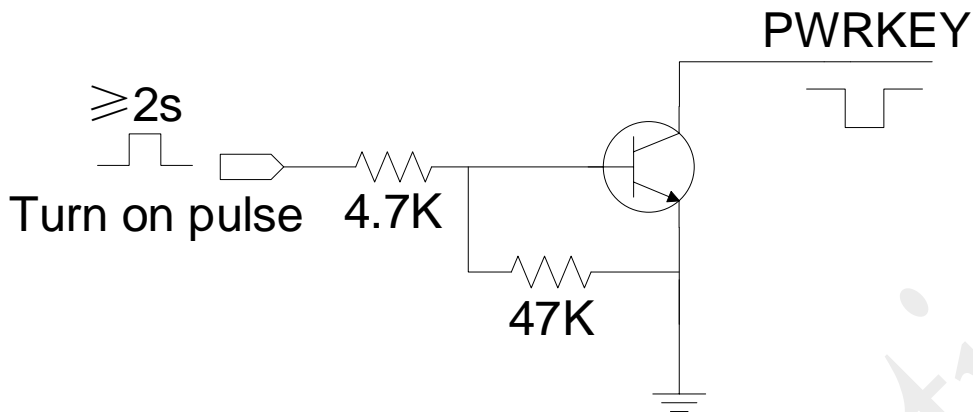

FIG. 6 Open set drive reference boot circuit

Another way to control the PWRKEY pin is through a switch button. A TVS is placed near the button for ESD protection. The reference circuit shows below:

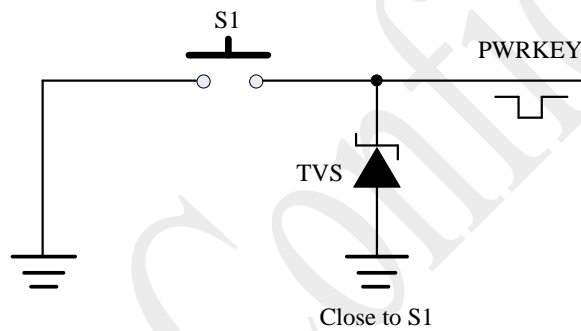

FIG. 7 Button startup reference circuit

The boot sequence is shown in the figure below:

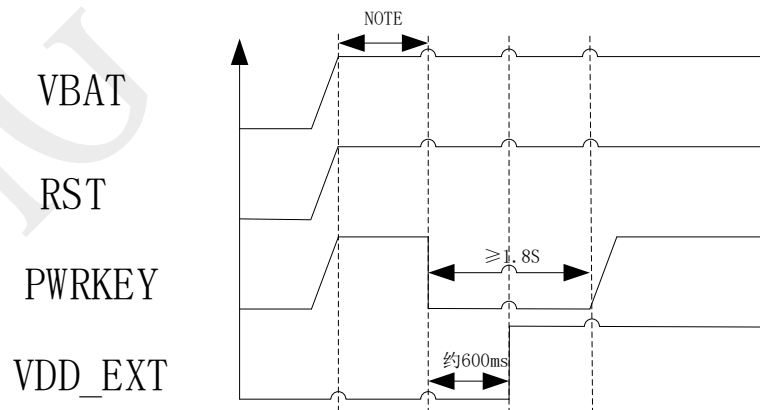

FIG.1 Power-on sequence diagram

Remarks:

Before pulling down PWRKEY pin, VBAT voltage should be stable indeed. It is recommended that the time interval between powering up VBAT and pulling down PWRKEY pins should be no less than 30ms.

If the module needs to be powered on and started automatically, PWRKEY pin can be directly pointed to the ground. The resistance value to earth should not exceed 1k at most. It is recommended to use 0R. This way the module is shut down, only direct power off.

3.5.2 Shutdown

Table 8 Description of three shutdown modes of the module:

Shutdown method	Shutdown step	Applicable scene
Low voltage shutdown	When VBAT voltage is too low or power is lost, the module will shut down	At this point, the module did not carry out the normal shutdown process, did not follow the process of logout from the base station
Hardware shutdown	Pull down PWRKEY(greater than 3. s) and release	Normal_shutdown
ATshutdown	AT+CPOF	Soft power-off

Remarks:

1. When the module is working normally, do not immediately cut off the power supply of the module to avoid damaging the Flash data inside the module. It is strongly recommended to close the module through the AT command before disconnecting the power.

2. When using the AT command to shut down, make sure that PWRKEY is in a high level state, otherwise, the module will start up again automatically after the shutdown is completed

3.6 Reset

There are two SLM336 reset modes: hardware reset and AT command reset.

3.6.1 Hardware Reset

When the module is working, lower the RESET_N pin by at least 150ms to reset the module. RESET_N signal is sensitive to interference, so it suggests that the routing on the module interface board should be as short as possible and should be processed in package.

The reference circuit is similar to the PWRKEY control circuit, and the customer can control the RESET_N pin using an open set drive circuit or a button.

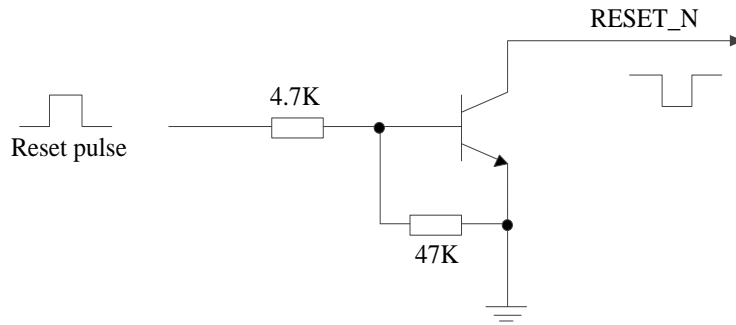

Figure 9. RESET_N reset the open set reference circuit

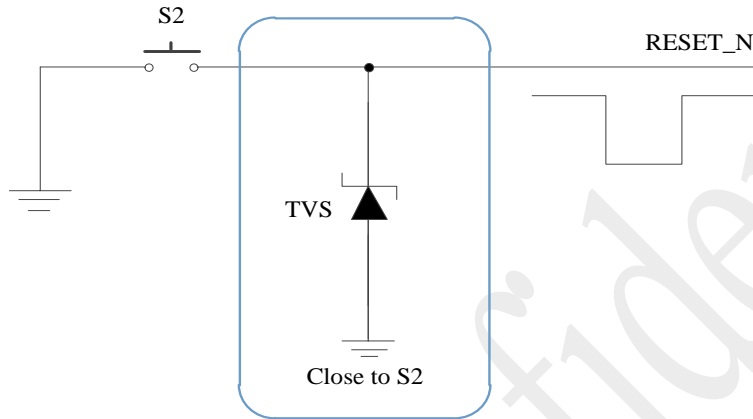

Figure 10 RESET_N reset button reference circuit

The reset sequence diagram is as follows:

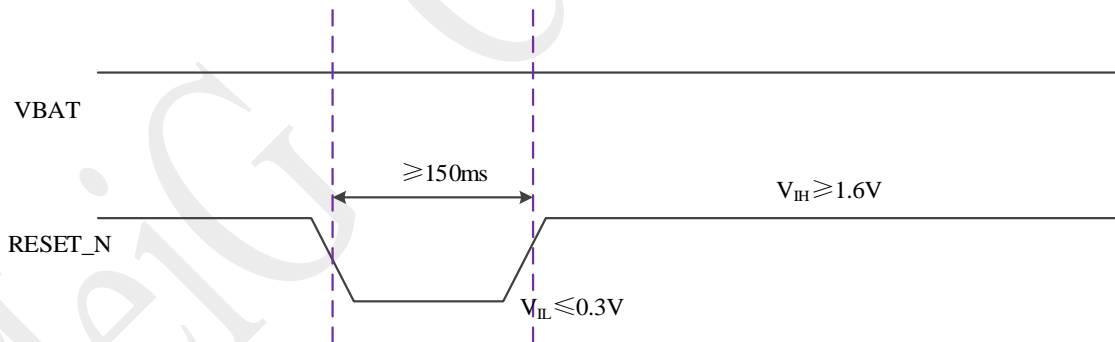

Figure 11 RESET_N reset sequence diagram

3.6.2 AT Command Reset

Through SLM336 UART or USB AT port, enter AT+TRB command, make SLM336 reset and restart.

3.7 USIM/SIM Port

SLM336 supports 1.8V and 3.0V USIM/SIM CARDS.

Table9 USIM/SIM interface description

Pin Name	I/O	Pin	Pin Description
USIM1_VDD	43	PO	(U)SIM1 Power
USIM1_DATA	45	DIO	(U)SIM1 data signal
USIM1_CLK	46	DO	(U)SIM1 clock signal
USIM1_RST	44	DO	(U)SIM1 reset signal
USIM1_DET	42	DI	(U)SIM1 Hot swap detection signal
USIM1_GND	47	G	(U)SIM1 GND
USIM2_VDD	87	PO	(U)SIM2 Power
USIM2_DATA	86	DIO	(U)SIM2 data signal
USIM2_CLK	84	DO	(U)SIM2 clock signal
USIM2_RST	85	DO	(U)SIM2 reset signal
USIM2_DET*	83*	DI	(U)SIM2 Hot swap detection signal

SLM336 supports USIM/SIM card hot-plugging function through USIM_DET pin and supports low level detection. After USIM/SIM card is inserted in the figure, USIM_DET pin is at low level. When USIM_DET pin is at high level, no card is detected.

The USIM/SIM card hot swap function can be configured by the "AT+SIMHOTSWAP" command. The instructions of the AT command are shown in the following table:

Table 10 Description of USIM/SIM card hot-plug function setting

AT Command	USIM/SIM card hot swap detection	Function Description
AT+SIMHOTSWAP=1	open	By default, the USIM/SIM card hot-plug detection function is on, and the module detects whether the SIM card is inserted through the USIM_DET pin status
AT+SIMHOTSWAP=0	close	The USIM/SIM card hot-plug detection function is turned off. The USIM/SIM card will be read by the module when the machine is turned on. The USIM_DET status will not be detected

When the USIM_DET is low level, the module will execute the USIM/SIM card initializer when it detects the SIM card insertion. After reading the USIM/SIM card information, the module will register the network. When USIM_DET is high power, the module determines that the USIM/SIM card is pulled out and the USIM/SIM card will not be read. USIM_DET defaults to a low trigger level, which can be set using the AT command.

Table 11 Description of SLM336 module 1.8V voltage output interface

AT Command	Function Description
AT+GTSET=1	High level detection
AT+GTSET=0	Default, low level detection

The circuit design shows in the follow figure, with USIM/SIM card hot swap function.

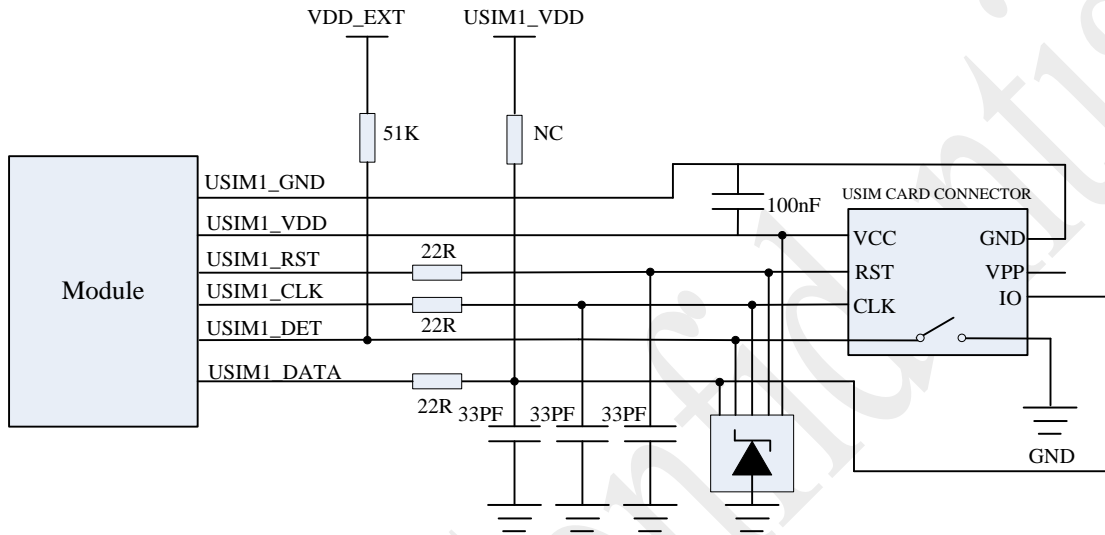

FIG. 12 Reference design drawing of the booth with hot-plug function

If you do not need USIM/SIM card hot-plug detection, keep the USIM1_DET pin dangling, log off the USIM/SIM interrupt detection pin. The reference circuit is as follows::

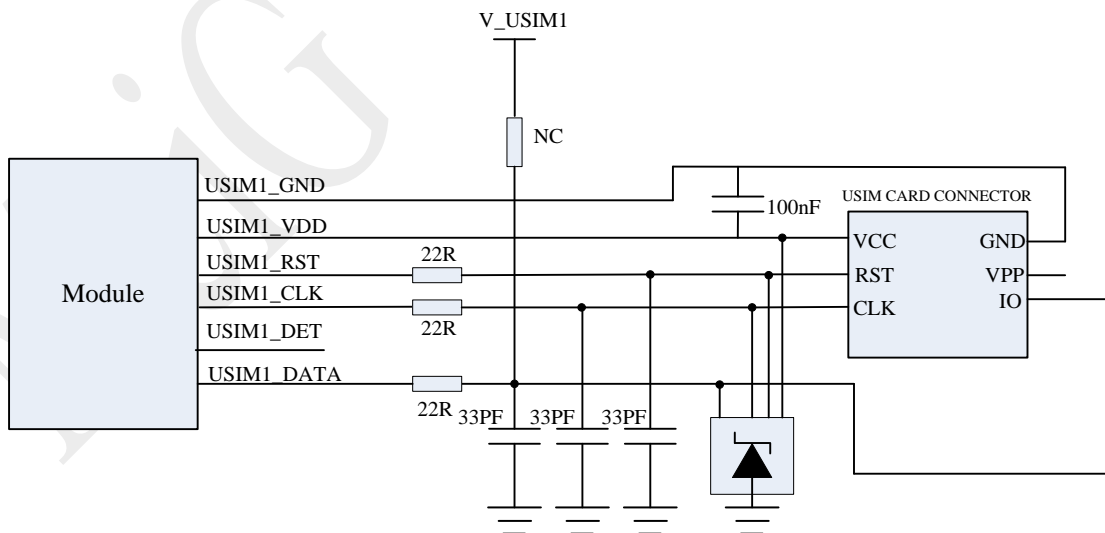

FIG. 13 Reference design drawing of the booth without hot-plugging function

In the circuit design of USIM card interface, in order to ensure the good performance and reliability of USIM card, the following design principles are recommended in the circuit design:

- In USIM_DATA USIM_CLK and USIM_RST lines on a 22Ω resistance, used to suppress the spurious EMI, enhance ESD protection, and convenient debugging;
- In order to improve the antistatic ability, TVS are added on USIM_VDD, USIM_DATA, USIM_CLK and USIM_RST lines, ESD protection devices with parasitic capacitance no more than 15Pf;
- 33pF capacitors in parallel on USIM_VDD, USIM_DATA, USIM_CLK and USIM_RST lines are used to filter out GSM900 interference. The peripheral devices of the USIM card shall be placed as close as possible to the USIM booth;
- USIM booth is placed close to the module to ensure that the wiring length of USIM card signal line does not exceed 100mm;
- SIM card signal lines are wired away from RF lines and VBAT power lines;
- In order to prevent USIM_CLK signals from crosstalk with USIM_DATA, the two wires should not be too close together and an additional shielding should be added between the two wires.

3.8 USB Interface

The SLM336 provides a USB interface conforming to the USB 2.0 standard. This interface is used for AT command interaction, data transfer, software debugging and version upgrading, etc.

3.8.1 USB Pin Description

The SLM336 module provides a USB2.0 interface.

Table 12 DESCRIPTION of USB interface

Pin Name	I/O	Pin	Description
USB_VBUS	AI	8	USB Insert the test
USB_DP	AIO	9	USB Differential data +
USB_DM	AIO	10	USB Differential data -
GND	G	3,31,48,50,54,55,58,59,61,62,67~74 ,79~82,89~91,100~102	GND

3.8.2 USB Reference Circuit

The SLM336 module USB interface application reference circuit is shown in the figure below.

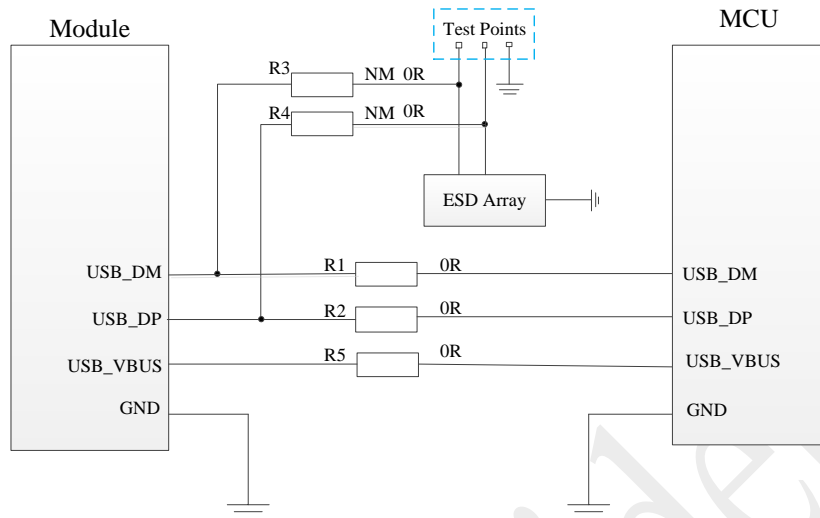

Figure 14. Refer to the design of the USB interface

In order to meet the signal integrity requirement of USB data line, R1/R2/R3/R4 resistors must be placed close to the module and between resistors close to each other. The branch connecting the test point must be as short as possible.

In USB interface circuit design, to ensure USB performance, the following principles are recommended in circuit design:

- The module USB_VBUS is not used to power the module, but to detect USB insertion and unplugging;
- In order to reduce the USB high speed data transmission of signal interference, in USB_DM USB_DP interface circuit and concatenated R1 and R2 can improve the accuracy of data transmission, 0 Ω R1 and R2 are recommended;
- In order to improve the antistatic performance of USB interface, ESD protective devices are recommended to be added to USB_DP and USB_DM interface circuits, and ESD devices with junction capacitance less than 1pF are recommended. USB ESD protection device should be placed as close as possible to USB interface;
- In order to ensure the USB work reliable, the design still need more consideration to the protection of USB, such as the Layout of the protection of the USB, need to do to USB_DP and USB_DM 90 Ω impedance control, strictly in accordance with the requirements of the differential line, as far as possible away from the interference signal;
- Do not use USB cable under crystal oscillator, oscillator, magnetic device and RF signal. It is recommended to use inner differential wiring and wrap the ground left, right, up and down.

3.9 Serial Port

SLM336 module has three serial ports: main serial port MAIN_UART, AUX_UART, DEBUG UART. The main features of the main serial port MAIN_UART, AUX_UART, DEBUG UART are described below.

- The main serial port supports 4800Bps, 9600bps, 19200Bps, 38400Bps, 57600bps, 115200Bps, 230400bps, 460800bps, 92160bps baud rate. The default baud rate is 115200bps for data transmission and AT command transmission.
- Debugging serial port support 115200bps baud rate, for r & D debugging use.
- AUX_UART is used as an auxiliary serial data communication.

Table 13 Main serial port pin description

Pin Name	I/O	Pin	Description
MAIN_RI	DO	39	Main serial port output ringing prompt
MAIN_DCD	DO	38	Main UART output carrier detection
MAIN_RTS	DI	37	Main UART Request to send data
MAIN_CTS	DO	36	Main UART clear send
MAIN_DTR	DI	30	The main serial data terminal is ready
MAIN_TXD	DO	35	Main UART TX
MAIN_RXD	DI	34	Main UART RX

Table 14 Description of AUX_UART port pin

Pin Name	I/O	PIN	Description
AUX_TXD	DO	27	AUX_UART TX
AUX_RXD	DI	28	AUX_UART RX

Table 15 Description of debugging serial port pin

Pin Name	I/O	PIN	Description
----------	-----	-----	-------------

DBG_RXD	DI	22	DBG_UART RX
DBG_TXD	DO	23	DBG_UART TX

Table 16 Serial port logic level

Parameter	Min value	Max value	Units
V _{IL}	-0.3	0.6	V
V _{IH}	1.2	2.0	V
V _{OL}	0	0.45	V
V _{OH}	1.35	1.8	V

The serial port level of SLM336 module is 1.8V. If the client host is 3.3V, the level converter needs to be added in the serial port application. TXB0104PWR of TI is recommended. The following picture is a reference design:

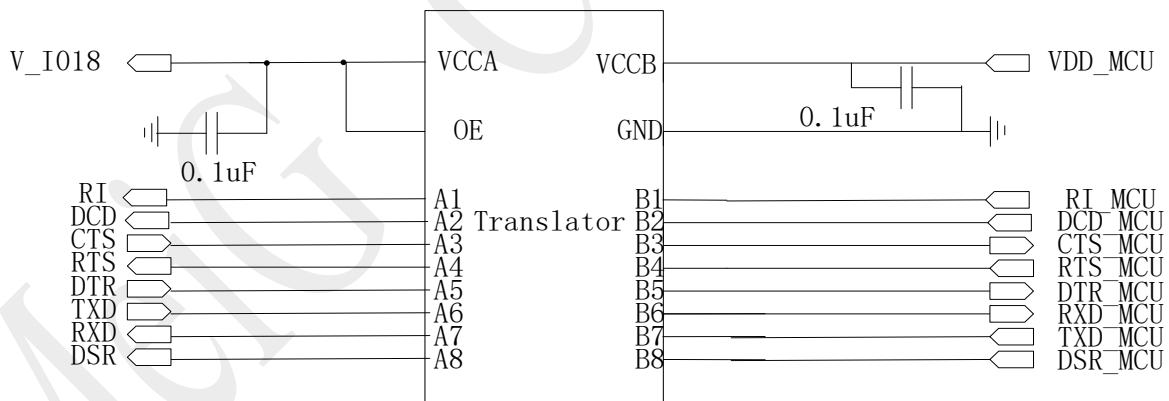

FIG. 15 Level conversion chip reference circuit

Another level conversion circuit is shown in the figure below. The input and output circuit design of the following dotted line section can refer to the solid line section, but pay attention to the connection direction. At the same time, this level conversion circuit is not suitable for applications with baud rate over 460Kbps.

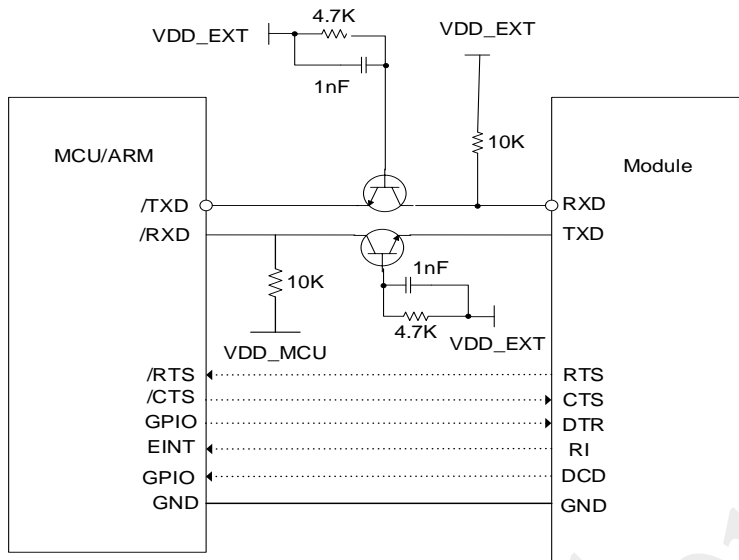

FIG. 16 UART signal connection

Note: During design, it is recommended to reserve 0R resistance and parallel capacitor positions on the main serial port and debug serial port circuit, which can be added to the baseplate to prevent RF interference.

3.10 Status Indication

The status indicator pin is mainly used to drive network status indicator light. SLM336 module has NET_STATUS and STATUS two network STATUS pins. The following two tables describe the pin definition and logic level changes in different network states.

Table 17 Description of network indicator pins

Pin Name	I/O	Pin	Description
STATUS	DO	20	Running status indication
NET_STATUS	DO	21	Network status indication

Table 18 Network indicates the working status of pins

Pin Name	Pin working state	Indicated working state
NET_STATUS	High level	Register LTE network status
	Low level	Else

The reference circuit is shown in the figure below:

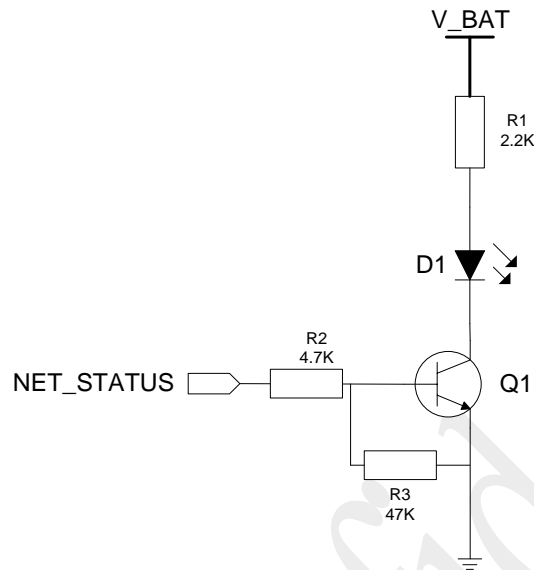

Figure 17 Network indication reference design drawing

NET_STATUS is used to indicate the working state of the module. The customer can connect this pin to the pull-up GPIO on the device tape. When the module is turned on normally, the default high impedance state of NET_STATUS is.

3.11 Low Power Mode

3.11.1 Flight Mode

Table 19 W_DISABLE# pin descriptions:

Pin Name	I/O	Pin	Description
W_DISABLE#	DI	18	Flight mode control

SLM336 module supports two ways to enter flight mode:

Table20 Description of flight mode Settings

1	Hardware I/O interface button control	W_DISABLE# for high or hovering (default is pull-up) is normal mode, and low is flight mode
2	AT command control	AT+CFUN=0-- go into airplane mode AT+CFUN=1-- go into normal mode

3.11.2 ULPS

Use the following AT instruction to put the module into ultra-low power mode (for power test)

AT^TRACECTRL=0, 0

AT^TRACECTRL=1, 0

AT+CSCLK=2

3.12 ADC Mode

SLM336 provides a two-way 12-bit analog-digital conversion interface, and the ADC voltage range is 0-VBAT.

Table 21 ADC pin description

Pin Name	I/O	Pin	Description
ADC0	AI	24	Analog to digital converter interface 0
ADC1	AI	2	Analog to digital converter interface 1

Remark:

1. In the case that VBAT is not powered, the ADC interface cannot directly connect any input voltage
2. It is recommended that the ADC pin be input with voltage divider circuit.
3. It is suggested that ADC should be wrapped when wiring, which can improve the accuracy of ADC voltage measurement.

3.13 USB_BOOT Interface

SLM336 supports USB_BOOT. The client can shorten USB_BOOT and VDD_EXT before starting

the module, and then the module will enter the forced download mode. In this mode, the module can be upgraded via USB interface.

Table 22 USB_BOOT pin definition

Pin Name	I/O	Pin	Description
USB_BOOT	DI	75	Short connect USB_BOOT and VDD_EXT before starting the module, and then the module will enter the forced download mode
VDD_EXT	PO	29	

3.14 AUDIO Interface

Table 23 AUDIO pin definition

Pin Name	I/O	Pin	Description
MIC_N	AI	119	Microphone input channel (-)
MICBIAS	PO	120	Microphone bias voltage output
SPK_P	AO	121	Analog audio differential output channel (+)
SPK_N	AO	122	Analog audio differential output channel (-)
MIC_P	AI	126	Microphone input channel (+)

3.15 PCM Interface

Table 24 PCM pin definition

Pin Name	I/O	Pin	Description
PCM_CLK	DI	4	PCM clock signal Leave empty if not used

PCM_SYNC	DI	5	PCM frame signal synchronization Leave empty if not used
PCM_DIN	DI	6	PCM data input signal Leave empty if not used
PCM_DOUT	DO	7	PCM data output signal Leave empty if not used

3.16 I2C Interface

Table 25 I2C pin definition

Pin Name	I/O	Pin	Description
I2C_SCL	OD	40	I2C serial clock Leave empty if not used
I2C_SDA	OD	41	I2C serial data Leave empty if not used

3.17 SPI Port

SPI interface only supports main mode, and communicates with peripherals through synchronous duplex serial mode. The working voltage is 1.8V. When the universal 4-wire SPI interface is used to connect to Nor Flash, it supports basic operations such as reading, writing, erasing, etc., and needs to be erased and protected by itself. It does not support the file system and can only be stored.

Table 26 SPI pin definition

Pin Name	I/O	Pin	Description
SPI_CLK	DO	26	SPI CLK Leave empty if not used

SPI_CS	DO	25	SPI chip selection Leave empty if not used
SPI_DIN	DI	88	SPI Main mode input Leave empty if not used
SPI_DOUT	DO	64	SPI Main mode output Leave empty if not used

3.18 Function Multiplexing Interface

Table 27 Pin definition of multiplexing function

Pin Name	Pin	Default mode	Mode 0	Mode 1	Mode 2	Mode 3
PSM_IND	1	gpio_4	spi_flash1_sio_2			
PCM_CLK	4	i2s2_bck	gpio_0	spi_flash1_clk	spi_2_clk	i2s2_bck
PCM_SYNC	5	i2s2_lrck	gpio_1	spi_flash1_cs	spi_2_cs_0	i2s2_lrck
PCM_DIN	6	i2s2_sdat_i	gpio_2	spi_flash1_sio_0	spi_2_dio_0	i2s2_sdat_i
PCM_DOUT	7	i2s2_sdat_o	gpio_3	spi_flash1_sio_1	spi_2_di_1	i2s2_sdat_o
W_DISABLE#	18	gpio_27	sdmmc1_ata_2*	gpio_27		
AP_READY	19	gpio_28	sdmmc1_ata_3*	gpio_28		
STATUS	20	gpio_5	gpio_5	spi_flash1		

				_sio_3		
NET_STATUS	21	gpio_13	gpio_13			
SPI_CS	25	spi_1_cs_0	gpio_10	spi_1_cs_0		
SPI_CLK	26	spi_1_clk	gpio_9	spi_1_clk		
AUX_TXD	27	uart_2_txd	gpio_21	uart_2_txd		
AUX_RXD	28	uart_2_rxd	gpio_20	uart_2_rxd		
MAIN_DTR	30	gpio_25	sdmmc1_data_0*	gpio_25		
MAIN_CTS	36	uart_1_cts	gpio_19	uart_1_cts		
MAIN_RTS	37	uart_1_rts	gpio_18	uart_1_rts		
MAIN_DCD	38	gpio_24	sdmmc1_cmd*	gpio_24		
MAIN_RI	39	gpio_26	sdmmc1_data_1*	gpio_26		
I2C_SCL	40	i2c_m2_scl	gpio_14	i2c_m2_scl		
I2C_SDA	41	i2c_m2_sda	gpio_15	i2c_m2_sda		
USIM1_DET	42	gpio_23	gpio_23	uart_2_cts		
SPI_DOUT	64	spi_1_dio_0	gpio_11	spi_1_dio_0		
USIM2_DET*	83	gpio_22	gpio_22	uart_2_rts		

USIM2_CLK	84	sim_2_clk	sim_2_clk		gpio_29	
USIM2_RST	85	sim_2_rst	sim_2_rst		gpio_31	
USIM2_DATA	86	sim_2_dio	sim_2_dio		gpio_30	
SPI_DIN	88	spi_1_di_1	gpio_12	spi_1_di_1		

Remarks: "*" means under development.

4 Antenna Interface

SLM336 module design interface, there are two antenna, the antenna impedance 50Ω.

Table 19 Definition of pin of antenna interface

Pin Name	Pin Number	Description	I/O	Remark
ANT_MAIN	60	main antenna port	IO	50Ω impedance
ANT_BT/WIFI_SCAN	56	Bluetooth and Wi-Fi Scan Common antenna interface	IO	50Ω impedance

4.1 Antenna Interface

SLM336 provides two antenna pins: ANT_MAIN and ANT_BT/WIFI_SCAN to improve the product's FDD-LTE, WIFI/BT transceiver performance. Recommend users to use with the module, RF connector match 50 Ω impedance of the antenna.

Remark:

In order to ensure the communication capability of all frequency bands, please connect all antennas. It is recommended that applications carefully select RF wiring. RF wiring needs to be selected with minimal loss. RF wiring for RF loss requirements is recommended as follows:

- GSM850 <0.6dB;
- GSM900 <0.6dB;
- DCS1800 <1.0dB;
- DCS1900 <1.0dB
- FDD-LTE<1.2dB;
- WIFI/BT<1.2dB

4.2 RF Reference Circuit

4.2.1 Antenna Connection Reference Design

The reference circuit for antenna connection of ANT_MAIN, ANT_BT/WIFI_SCAN is shown in the figure below. In order to obtain better RF performance, the following four points should be paid attention to when designing schematic diagram and PCB layout:

1. Schematic design, near the module RF port reserved type matching circuit, capacitor default not attached;
2. Schematic design, redundant RF connectors between the RF port of the module and the antenna, used for certification test, RF connectors are not attached after mass production and delivery; (Reference: RF Connector C88P132-00001-H);
3. Schematic design, π type matching circuit is reserved near the antenna end, capacitor is not affixed by default;
4. PCB layout, Module RF port to the antenna between lines as short as possible, and need to plate factory for RF line do 50Ω impedance control.

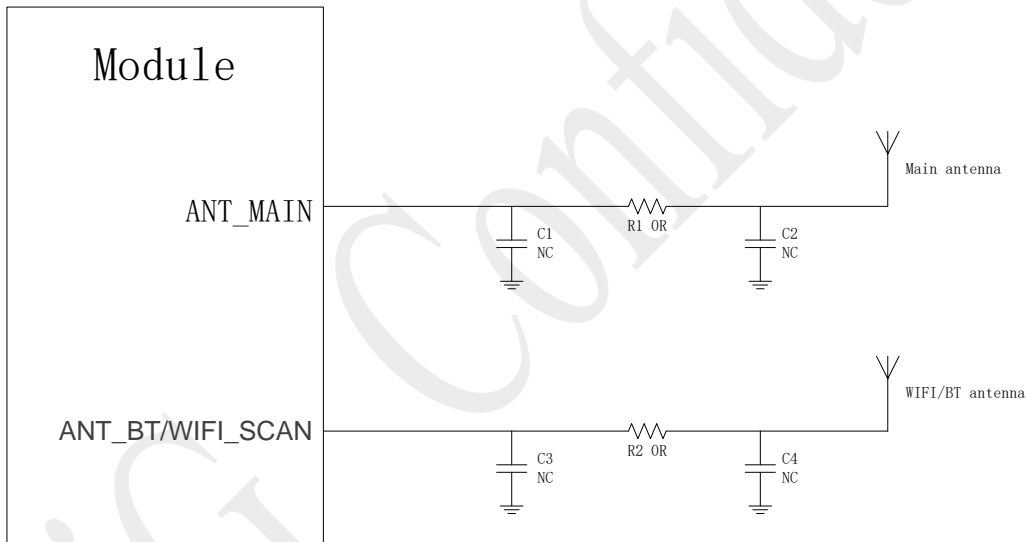

FIG. 19 Rf reference circuit

4.2.2 RF Signal Line Layout

For user PCB, the characteristic impedance of all RF signal lines should be controlled at 50ω . Generally, the impedance of RF signal line is determined by the dielectric constant of the material, the trace width (W), the ground clearance (S), and the height (H) of the reference ground plane. The characteristic impedance of PCB is usually controlled by microstrip line and coplanar waveguide. In order to embody the design principle, the following figures show the structural design of microstrip line and coplanar waveguide when the impedance line is controlled to 50Ω .

Microstrip line complete structure

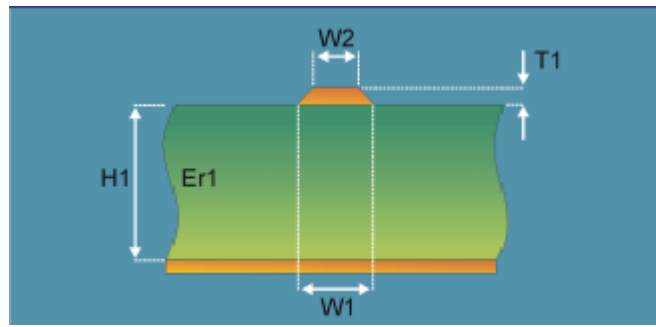

FIG. 20 Two-layer PCB microstrip line structure

Complete structure of coplanar waveguide

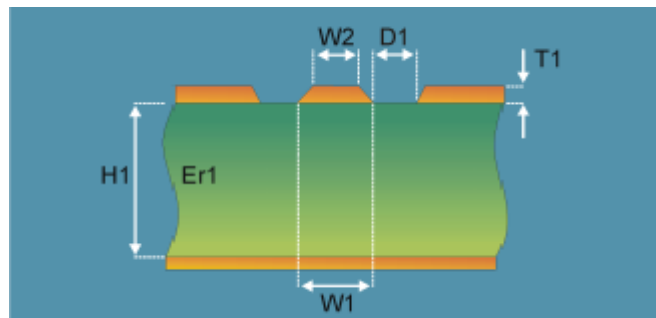

FIG. 21 Two-layer PCB coplanar waveguide structure

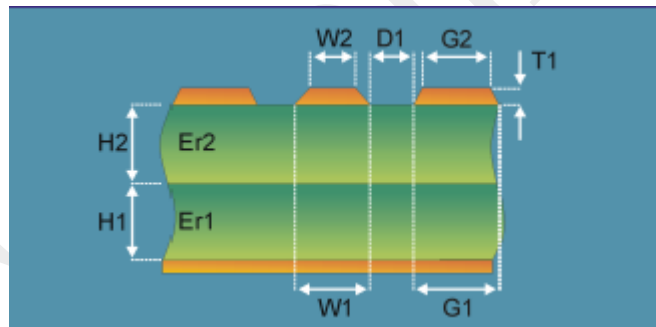

FIG. 22 Multi-layer PCB coplanar waveguide structure (the reference ground is the third layer)

In the circuit design of RF antenna interface, in order to ensure the good performance and reliability of RF signal, the following design principles are recommended:

- Precise 50Ω impedance control of the RF signal lines shall be performed using impedance simulation calculation tools.
- GND pin adjacent to the RF pin is not a hot pad, but should be fully contacted with the ground.
- The distance between RF pin and RF connector should be as short as possible; At the same time, avoid right-angle routing, and the recommended routing angle is 135°.
- Pay attention to the connection device package when it is established, and keep a certain distance from the ground for the signal pin.
- The reference ground plane of RF signal line should be complete; Adding a certain amount of ground holes around the signal line and the reference ground can help improve the RF performance; The distance between the ground hole and the signal line should be at least 2 times the line width (2

× W).

- RF signal lines must be far away from interference sources, and avoid crossing or parallel with any signal lines in adjacent layers.

4.3 Antenna Installation

4.3.1 Antenna Requirements

The requirements of main antenna receiving antenna are shown in the following table:

Table 29 Antenna requirements

Type	Requirement
GSM/FDD-LTE	VSWR: < 2
	increase (dBi) : 1
	Maximum output power (W) : 2W
	input impedance (ohm) : 50
	Type of polarization: vertical direction
	Cable insertion loss: < 1.5dB (GSM850/900/1800/1900;LTE B1/B3/B5/B7/B8/B20/B28)
	Cable insertion loss: < 2dB (LTE B38/B40/B41)
WIFI/BT	VSWR: < 2
	increase (dBi) : 1
	Maximum output power (W) : 0.1W
	input impedance (ohm) : 50
	Type of polarization: vertical direction
	Cable insertion loss: < 1.5dB

4.3.2 RF output power

The RF output power of SLM336 is shown in the following table.

Table 30 SLM336 RF transmission power

Frequency	Max	Min
GSM850	33dBm ± 2dB	5dBm ± 5dB
EGSM900	33dBm ± 2dB	5dBm ± 5dB
DSM1800	30dBm ± 2dB	0dBm ± 5dB
PCS1900	30dBm ± 2dB	0dBm ± 5dB
LTE-FDD B1	23dBm ± 2.7dB	<-39dBm
LTE-FDD B3	23dBm ± 2.7dB	<-39dBm
LTE-FDD B5	23dBm ± 2.7dB	<-39dBm
LTE-FDD B7	23dBm ± 2.7dB	<-39dBm

LTE-FDD B8	23dBm±2.7dB	<-39dBm
LTE-TDD B20	23dBm±2.7dB	<-39dBm
LTE-TDD B28	23dBm±2.7dB	<-39dBm

4.3.3 RF Frequency

Table 31 SLM336 module RF reception sensitivity

Frequency	Reception sensitivity (typical value BW) -10M			3GPP (Dominant+Diversity)
	Dominant set	Diversity	Dominant+Diversity	
GSM850	-108dBm	NA	NA	-102.4dBm
EGSM900	-108dBm	NA	NA	-102.4dBm
DCS1800	-108dBm	NA	NA	-102.4dBm
PCS1900	-108dBm	NA	NA	-102.4dBm
LTE-FDD B1	-98dBm	NA	NA	-96.3dBm
LTE-FDD B3	-97dBm	NA	NA	-94.3dBm
LTE-FDD B5	-98dBm	NA	NA	-93.3dBm
LTE-FDD B7	-98dBm	NA	NA	-94.3dBm
LTE-FDD B8	-98dBm	NA	NA	-93.3dBm
LTE-FDD B20	-98dBm	NA	NA	-94.8dBm
LTE-TDD B28	-98dBm	NA	NA	-94.8dBm

Remark:

Other sub-model and frequency information will be reflected in subsequent versions of the document.

4.3.4 Working Frequency

Table 32 SLM336 operating frequency

Frequency band	send	receive	units
GSM850	824~849	869~894	MHz
EGSM900	880~915	925~960	MHz
DCS1800	1710~1785	1805~1880	MHz
PCS1900	1850~1909	1930~1989	MHz
LTE-FDD B1	1920~1980	2110~2170	MHz
LTE-FDD B3	1710~1785	1805~1880	MHz
LTE-FDD B5	824~849	869~894	MHz
LTE-FDD B7	2500~2570	2620~2690	MHz
LTE-FDD B8	880~915	925~960	MHz
LTE-FDD B20	832~862	791~821	MHz
LTE-FDD B28	703~748	758~803	MHz
WIFI/BT	2400-2483	2400-2483	MHZ

4.3.5 OTA Antenna Requirements

Table 33 Antenna index requirements

Network Mode	Band	VSWR	Gain		Effi.	SAR	TRP (dBm)	TIS (dBm)
			Peak	Avg.				
GSM	850	<2.5:1	>0dBi	>-4dBi	>40%	<1.6W/Kg	25	<-101
	900						25	<-101
	1800(DCS)						25	<-101
	1900(DCS)						24	<-101
FDD-LTE	Band1	<2.5:1	>0dBi	>-4dBi	>40%	<1.6W/Kg	17	<-91
	Band3						17	<-91
	Band5						17	<-91
	Band7						17	<-91
	Band8						17	<-91
	Band20						17	<-91
	Band28						17	<-91
WIFI	2400	<2.5:1	>0dBi	>-4dBi	>40%	<1.6W/Kg	/	<-80
BT	2400	<2.5:1	>0dBi	>-4dBi	>40%	<1.6W/Kg	3	<-82

5 Electrical Characteristics

5.1 Limited Voltage Range

Limited voltage range refers to the maximum voltage range that the module supply voltage and digital and analog input/output interfaces can withstand. Work outside this range may cause damage to the product.

The limited voltage range of SLM336 is shown in the following table.

Table 34 Limited operating voltage range of modules

Parameters	Description	Min	Typical value	Max	units
VBAT	Power supply	-0.3	3.8	5.5	V
GPIO	Digital I/O level supply voltage	-0.3	1.8	2.0	V
VBUS	USB Insert the test	-0.3	5.0	5.5	V

5.2 Ambient Temperature Range

The SLM336 module is recommended to operate at $-30\sim+75^{\circ}\text{C}$. It is suggested that temperature control measures should be considered at the application end under adverse environmental conditions. At the same time, the extended operating temperature range of the module is provided. When used at the extended temperature, the function is normal, and some RF indicators may deteriorate. It is also recommended that the module application terminal be stored at a certain temperature. Modules outside this range may not work properly or may be damaged.

Table35 Temperature range of module

Parameters	Min	Typical value	Max	Units
Operating temperature	-30	+25	+75	$^{\circ}\text{C}$
Storage temperature	-40		+85	$^{\circ}\text{C}$

5.3 Electrical Characteristics of Interface Working State

V_L : Logic low level;

V_H : Logic high level.

Table 27 The logic level of a normal digital IO signal

Signal	V_L		V_H		Units
	Min	Max	Min	Max	
digital input	-0.3	0.6	1.2	2.0	V
digital output		0.45	1.35		V

Table 28 Electrical characteristics of power supply operating state

Parameters	I/O	Min	Model	Max	Units
VBAT	I	3.5	3.8	4.2	V
VBUS	I	4.5	5.0	5.5	V
USIM_VDD	O	1.7/2.75	1.8/2.85	1.9/2.95	V

5.4 Power Consumption Range

Table 38 Power consumption

State of the module	Test item	Test Case	Result (mA)
Power off	Shutdown leakage current	Maintain normal voltage (3.8V) power supply in case of power failure	42uA
Dormant	Real network	Insert the mobile card, the actual network standby, use the AT command to query the registration on the network, and record the average current of 10 minutes.	

	dormancy	Insert the unicom card, the actual network standby, use AT command to query and register the network, and record the 10-minute average current.		
		Insert the telecom card, the actual network standby, use AT command to query and register the network, and record the average current of 10 minutes.		
	GSM850	GSM850 CH128	<p>1) The tested module was powered on, and the data network was successfully registered;</p> <p>2) Set the module to sleep state through AT instruction (USB is in suspended state);</p> <p>3) Under the condition of no data transmission, the tested module maintained for 10 minutes and recorded the average current for 10 minutes.</p>	
		GSM850 CH190	<p>1) The tested module was powered on, and the data network was successfully registered;</p> <p>2) Set the module to sleep state through AT instruction (USB is in suspended state)</p> <p>3) Under the condition of no data transmission, the tested module maintained for 10 minutes and recorded the average current for 10 minutes.</p>	
GSM850 CH251		<p>1) The tested module was powered on, and the data network was successfully registered;</p> <p>2) Set the module to sleep state through AT instruction (USB is in suspended state);</p> <p>3) Under the condition of no data transmission, the tested module maintained for 10 minutes and recorded the average current for 10 minutes.</p>		
	GSM900	GSM900 CH975	<p>1) The tested module was powered on, and the data network was successfully registered;</p>	

		<p>2) Set the module to sleep state through AT instruction (USB is in suspended state);</p> <p>3) Under the condition of no data transmission, the tested module maintained for 10 minutes and recorded the average current for 10 minutes.</p>	
		<p>GSM900 CH38</p> <p>1) The tested module was powered on, and the data network was successfully registered;</p> <p>2) Set the module to sleep state through AT instruction (USB is in suspended state);</p> <p>3) Under the condition of no data transmission, the tested module maintained for 10 minutes and recorded the average current for 10 minutes.</p>	
		<p>GSM900 CH124</p> <p>1) The tested module was powered on, and the data network was successfully registered;</p> <p>2) Set the module to sleep state through AT instruction (USB is in suspended state);</p> <p>3) Under the condition of no data transmission, the tested module maintained for 10 minutes and recorded the average current for 10 minutes.</p>	
	DCS	<p>DCS CH698</p> <p>1) The tested module was powered on, and the data network was successfully registered;</p> <p>2) Set the module to sleep state through AT instruction (USB is in suspended state);</p> <p>3) Under the condition of no data transmission, the tested module maintained for 10 minutes and recorded the average current for 10 minutes.</p>	
		<p>DCS CH512</p> <p>1) The tested module was powered on, and the data network was successfully registered;</p> <p>2) Set the module to sleep state through AT instruction (USB is in suspended state);</p>	

		<p>3) Under the condition of no data transmission, the tested module maintained for 10 minutes and recorded the average current for 10 minutes.</p>	
		<p>DCS CH885</p> <p>1) The tested module was powered on, and the data network was successfully registered;</p> <p>2) Set the module to sleep state through AT instruction (USB is in suspended state);</p> <p>3) Under the condition of no data transmission, the tested module maintained for 10 minutes and recorded the average current for 10 minutes.</p>	
	PCS	<p>PCS CH661</p> <p>1) The tested module was powered on, and the data network was successfully registered;</p> <p>2) Set the module to sleep state through AT instruction (USB is in suspended state);</p> <p>3) Under the condition of no data transmission, the tested module maintained for 10 minutes and recorded the average current for 10 minutes.</p>	
		<p>PCS CH512</p> <p>1) The tested module was powered on, and the data network was successfully registered;</p> <p>2) Set the module to sleep state through AT instruction (USB is in suspended state);</p> <p>3) Under the condition of no data transmission, the tested module maintained for 10 minutes and recorded the average current for 10 minutes.</p>	
		<p>PCS CH810</p> <p>1) The tested module was powered on, and the data network was successfully registered;</p> <p>2) Set the module to sleep state through AT instruction (USB is in suspended state);</p> <p>3) Under the condition of no data transmission, the tested module maintained for 10 minutes and recorded the</p>	

			average current for 10 minutes.	
	FDD	The module is powered on, and the DRX monitoring period of the idle state on the network is 1.28s With no data transfer, the USB is in a suspended state	<p>Band1 CH18300</p> <p>1) The tested module was powered on, and the data network was successfully registered;</p> <p>2) Set the module to sleep state through AT instruction (USB is in suspended state);</p> <p>3) Under the condition of no data transmission, the tested module maintained for 10 minutes and recorded the average current for 10 minutes.</p>	
			<p>Band1 CH18050</p> <p>1) The tested module was powered on, and the data network was successfully registered;</p> <p>2) Set the module to sleep state through AT instruction (USB is in suspended state);</p> <p>3) Under the condition of no data transmission, the tested module maintained for 10 minutes and recorded the average current for 10 minutes.</p>	
			<p>Band1 CH19575</p> <p>1) The tested module was powered on, and the data network was successfully registered;</p> <p>2) Set the module to sleep state through AT instruction (USB is in suspended state);</p> <p>3) Under the condition of no data transmission, the tested module maintained for 10 minutes and recorded the average current for 10 minutes.</p>	
			<p>Band3 CH19575</p> <p>1) The tested module was powered on, and the data network was successfully registered;</p> <p>2) Set the module to sleep state through AT instruction (USB is in suspended state);</p> <p>3) Under the condition of no data transmission, the tested module maintained for 10 minutes and recorded the</p>	

			average current for 10 minutes.	
			<p>Band3 CH19250</p> <p>1) The tested module was powered on, and the data network was successfully registered;</p> <p>2) Set the module to sleep state through AT instruction (USB is in suspended state);</p> <p>3) Under the condition of no data transmission, the tested module maintained for 10 minutes and recorded the average current for 10 minutes.</p>	
			<p>Band3 CH19900</p> <p>1) The tested module was powered on, and the data network was successfully registered;</p> <p>2) Set the module to sleep state through AT instruction (USB is in suspended state);</p> <p>3) Under the condition of no data transmission, the tested module maintained for 10 minutes and recorded the average current for 10 minutes.</p>	
			<p>Band5 CH20525</p> <p>1) The tested module was powered on, and the data network was successfully registered;</p> <p>2) Set the module to sleep state through AT instruction (USB is in suspended state);</p> <p>3) Under the condition of no data transmission, the tested module maintained for 10 minutes and recorded the average current for 10 minutes.</p>	
			<p>Band5 CH20450</p> <p>1) The tested module was powered on, and the data network was successfully registered;</p> <p>2) Set the module to sleep state through AT instruction (USB is in suspended state);</p> <p>3) Under the condition of no data transmission, the tested module maintained for 10 minutes and recorded the</p>	

			average current for 10 minutes.	
			<p>Band5 CH20600</p> <ol style="list-style-type: none"> 1) The tested module was powered on, and the data network was successfully registered; 2) Set the module to sleep state through AT instruction (USB is in suspended state); 3) Under the condition of no data transmission, the tested module maintained for 10 minutes and recorded the average current for 10 minutes. 	
			<p>Band7 CH20800</p> <ol style="list-style-type: none"> 1) The tested module was powered on, and the data network was successfully registered; 2) Set the module to sleep state through AT instruction (USB is in suspended state); 3) Under the condition of no data transmission, the tested module maintained for 10 minutes and recorded the average current for 10 minutes. 	
			<p>Band7 CH21100</p> <ol style="list-style-type: none"> 1) The tested module was powered on, and the data network was successfully registered; 2) Set the module to sleep state through AT instruction (USB is in suspended state); 3) Under the condition of no data transmission, the tested module maintained for 10 minutes and recorded the average current for 10 minutes. 	
			<p>Band7 CH21400</p> <ol style="list-style-type: none"> 1) The tested module was powered on, and the data network was successfully registered; 2) Set the module to sleep state through AT instruction (USB is in suspended state); 3) Under the condition of no data transmission, the tested module maintained for 10 minutes and recorded the 	

			average current for 10 minutes.	
			<p>Band8 CH21625</p> <p>1) The tested module was powered on, and the data network was successfully registered;</p> <p>2) Set the module to sleep state through AT instruction (USB is in suspended state);</p> <p>3) Under the condition of no data transmission, the tested module maintained for 10 minutes and recorded the average current for 10 minutes.</p>	
			<p>Band8 CH21500</p> <p>1) The tested module was powered on, and the data network was successfully registered;</p> <p>2) Set the module to sleep state through AT instruction (USB is in suspended state);</p> <p>3) Under the condition of no data transmission, the tested module maintained for 10 minutes and recorded the average current for 10 minutes.</p>	
			<p>Band8 CH21750</p> <p>1) The tested module was powered on, and the data network was successfully registered;</p> <p>2) Set the module to sleep state through AT instruction (USB is in suspended state);</p> <p>3) Under the condition of no data transmission, the tested module maintained for 10 minutes and recorded the average current for 10 minutes.</p>	
			<p>Band20 CH242000</p> <p>1) The tested module was powered on, and the data network was successfully registered;</p> <p>2) Set the module to sleep state through AT instruction (USB is in suspended state);</p> <p>3) Under the condition of no data transmission, the tested module maintained for 10 minutes and recorded the</p>	

			average current for 10 minutes.	
			<p>Band20 CH243000</p> <p>1) The tested module was powered on, and the data network was successfully registered;</p> <p>2) Set the module to sleep state through AT instruction (USB is in suspended state);</p> <p>3) Under the condition of no data transmission, the tested module maintained for 10 minutes and recorded the average current for 10 minutes.</p>	
			<p>Band20 CH244000</p> <p>1) The tested module was powered on, and the data network was successfully registered;</p> <p>2) Set the module to sleep state through AT instruction (USB is in suspended state);</p> <p>3) Under the condition of no data transmission, the tested module maintained for 10 minutes and recorded the average current for 10 minutes.</p>	
			<p>Band28A CH27260</p> <p>1) The tested module was powered on, and the data network was successfully registered;</p> <p>2) Set the module to sleep state through AT instruction (USB is in suspended state);</p> <p>3) Under the condition of no data transmission, the tested module maintained for 10 minutes and recorded the average current for 10 minutes.</p>	
			<p>Band28A CH27310</p> <p>1) The tested module was powered on, and the data network was successfully registered;</p> <p>2) Set the module to sleep state through AT instruction (USB is in suspended state);</p> <p>3) Under the condition of no data transmission, the tested module maintained for 10 minutes and recorded the</p>	

			average current for 10 minutes.	
			<p>Band28A CH21359</p> <ol style="list-style-type: none"> 1) The tested module was powered on, and the data network was successfully registered; 2) Set the module to sleep state through AT instruction (USB is in suspended state); 3) Under the condition of no data transmission, the tested module maintained for 10 minutes and recorded the average current for 10 minutes. 	
			<p>Band28B CH27460</p> <ol style="list-style-type: none"> 1) The tested module was powered on, and the data network was successfully registered; 2) Set the module to sleep state through AT instruction (USB is in suspended state); 3) Under the condition of no data transmission, the tested module maintained for 10 minutes and recorded the average current for 10 minutes. 	
			<p>Band28B CH27535</p> <ol style="list-style-type: none"> 1) The tested module was powered on, and the data network was successfully registered; 2) Set the module to sleep state through AT instruction (USB is in suspended state); 3) Under the condition of no data transmission, the tested module maintained for 10 minutes and recorded the average current for 10 minutes. 	
			<p>Band28A CH27609</p> <ol style="list-style-type: none"> 1) The tested module was powered on, and the data network was successfully registered; 2) Set the module to sleep state through AT instruction (USB is in suspended state); 3) Under the condition of no data transmission, the tested module maintained for 10 minutes and recorded the 	

			average current for 10 minutes.	
	TDD	The module is powered on, and the DRX monitoring period of the idle state on the network is 1.28s With no data transfer, the USB is in a suspended state	<p>Band1 CH18300</p> <p>1) The tested module was powered on, and the data network was successfully registered;</p> <p>2) Set the module to sleep state through AT instruction (USB is in suspended state);</p> <p>3) Under the condition of no data transmission, the tested module maintained for 10 minutes and recorded the average current for 10 minutes.</p>	
			<p>Band1 CH18050</p> <p>1) The tested module was powered on, and the data network was successfully registered;</p> <p>2) Set the module to sleep state through AT instruction (USB is in suspended state);</p> <p>3) Under the condition of no data transmission, the tested module maintained for 10 minutes and recorded the average current for 10 minutes.</p>	
			<p>Band1 CH118550</p> <p>1) The tested module was powered on, and the data network was successfully registered;</p> <p>2)Set the module to sleep state through AT instruction (USB is in suspended state);</p> <p>3) Under the condition of no data transmission, the tested module maintained for 10 minutes and recorded the average current for 10 minutes. .</p>	
			<p>Band3 CH19575</p> <p>1) The tested module was powered on, and the data network was successfully registered;</p> <p>2) Set the module to sleep state through AT instruction (USB is in suspended state);</p> <p>3) Under the condition of no data transmission, the tested module maintained for 10 minutes and recorded the</p>	

			average current for 10 minutes.	
			<p>Band3 CH19250</p> <p>1)The tested module was powered on, and the data network was successfully registered;</p> <p>2) Set the module to sleep state through AT instruction (USB is in suspended state);</p> <p>3) Under the condition of no data transmission, the tested module maintained for 10 minutes and recorded the average current for 10 minutes.</p>	
			<p>Band3 CH19900</p> <p>1) The tested module was powered on, and the data network was successfully registered;</p> <p>2) Set the module to sleep state through AT instruction (USB is in suspended state);</p> <p>3) Under the condition of no data transmission, the tested module maintained for 10 minutes and recorded the average current for 10 minutes.</p>	
			<p>Band5 CH20600</p> <p>1) The tested module was powered on, and the data network was successfully registered;</p> <p>2) Set the module to sleep state through AT instruction (USB is in suspended state);</p> <p>3) Under the condition of no data transmission, the tested module maintained for 10 minutes and recorded the average current for 10 minutes.</p>	
			<p>Band5 CH204500</p> <p>1) The tested module was powered on, and the data network was successfully registered;</p> <p>2) Set the module to sleep state through AT instruction (USB is in suspended state);</p> <p>3) Under the condition of no data transmission, the tested module maintained for 10 minutes and recorded the</p>	

			average current for 10 minutes.	
			<p>Band5 CH20525</p> <p>1) The tested module was powered on, and the data network was successfully registered;</p> <p>2) Set the module to sleep state through AT instruction (USB is in suspended state);</p> <p>3) Under the condition of no data transmission, the tested module maintained for 10 minutes and recorded the average current for 10 minutes.</p>	
			<p>Band7 CH20800</p> <p>1) The tested module was powered on, and the data network was successfully registered;</p> <p>2) Set the module to sleep state through AT instruction (USB is in suspended state);</p> <p>3) Under the condition of no data transmission, the tested module maintained for 10 minutes and recorded the average current for 10 minutes.</p>	
			<p>Band7 CH21100</p> <p>1) The tested module was powered on, and the data network was successfully registered;</p> <p>2) Set the module to sleep state through AT instruction (USB is in suspended state);</p> <p>3) Under the condition of no data transmission, the tested module maintained for 10 minutes and recorded the average current for 10 minutes.</p>	
			<p>Band7 CH21400</p> <p>1) The tested module was powered on, and the data network was successfully registered;</p> <p>2) Set the module to sleep state through AT instruction (USB is in suspended state);</p> <p>3) Under the condition of no data transmission, the tested module maintained for 10 minutes and recorded the</p>	

			average current for 10 minutes.	
			<p>Band8 CH21750</p> <p>1) The tested module was powered on, and the data network was successfully registered;</p> <p>2) Set the module to sleep state through AT instruction (USB is in suspended state);</p> <p>3) Under the condition of no data transmission, the tested module maintained for 10 minutes and recorded the average current for 10 minutes.</p>	
			<p>Band8 CH21625</p> <p>1) The tested module was powered on, and the data network was successfully registered;</p> <p>2) Set the module to sleep state through AT instruction (USB is in suspended state);</p> <p>3) Under the condition of no data transmission, the tested module maintained for 10 minutes and recorded the average current for 10 minutes.</p>	
			<p>Band8 CH21500</p> <p>1) The tested module was powered on, and the data network was successfully registered;</p> <p>2) Set the module to sleep state through AT instruction (USB is in suspended state);</p> <p>3) Under the condition of no data transmission, the tested module maintained for 10 minutes and recorded the average current for 10 minutes.</p>	
			<p>Band20 CH24200</p> <p>1) The tested module was powered on, and the data network was successfully registered;</p> <p>2) Set the module to sleep state through AT instruction (USB is in suspended state);</p> <p>3) Under the condition of no data transmission, the tested module maintained for 10 minutes and recorded the</p>	

			average current for 10 minutes.	
			<p>Band20 CH24300</p> <ol style="list-style-type: none"> 1) The tested module was powered on, and the data network was successfully registered; 2) Set the module to sleep state through AT instruction (USB is in suspended state); 3) Under the condition of no data transmission, the tested module maintained for 10 minutes and recorded the average current for 10 minutes. 	
			<p>Band20 CH24400</p> <ol style="list-style-type: none"> 1) The tested module was powered on, and the data network was successfully registered; 2) Set the module to sleep state through AT instruction (USB is in suspended state); 3) Under the condition of no data transmission, the tested module maintained for 10 minutes and recorded the average current for 10 minutes. 	
			<p>Band28A CH24260</p> <ol style="list-style-type: none"> 1) The tested module was powered on, and the data network was successfully registered; 2) Set the module to sleep state through AT instruction (USB is in suspended state); 3) Under the condition of no data transmission, the tested module maintained for 10 minutes and recorded the average current for 10 minutes. 	
			<p>Band28A CH27310</p> <ol style="list-style-type: none"> 1) The tested module was powered on, and the data network was successfully registered; 2) Set the module to sleep state through AT instruction (USB is in suspended state); 3) Under the condition of no data transmission, the tested module maintained for 10 minutes and recorded the 	

			average current for 10 minutes.	
			<p>Band28A CH27359</p> <p>1) The tested module was powered on, and the data network was successfully registered;</p> <p>2) Set the module to sleep state through AT instruction (USB is in suspended state);</p> <p>3) Under the condition of no data transmission, the tested module maintained for 10 minutes and recorded the average current for 10 minutes.</p>	
			<p>Band28B CH27460</p> <p>1) The tested module was powered on, and the data network was successfully registered;</p> <p>2) Set the module to sleep state through AT instruction (USB is in suspended state);</p> <p>3) Under the condition of no data transmission, the tested module maintained for 10 minutes and recorded the average current for 10 minutes.</p>	
			<p>Band28B CH27535</p> <p>1) The tested module was powered on, and the data network was successfully registered;</p> <p>2) Set the module to sleep state through AT instruction (USB is in suspended state);</p> <p>3) Under the condition of no data transmission, the tested module maintained for 10 minutes and recorded the average current for 10 minutes.</p>	
			<p>Band28B CH27609</p> <p>1) The tested module was powered on, and the data network was successfully registered;</p> <p>2) Set the module to sleep state through AT instruction (USB is in suspended state);</p> <p>3) Under the condition of no data transmission, the tested module maintained for 10 minutes and recorded the</p>	

			average current for 10 minutes.	
standby	FDD	The module is powered on, and the DRX monitoring period of the idle state on the network is 1.28s With no data transfer, USB is active	Band1 CH18300 Under the condition of no data transmission, the tested module maintained for 10 minutes and recorded the average current for 10 minutes.	
			Band1 CH18050 Under the condition of no data transmission, the tested module maintained for 10 minutes and recorded the average current for 10 minutes.	
			Band1 CH118550 Under the condition of no data transmission, the tested module maintained for 10 minutes and recorded the average current for 10 minutes.	
			Band3 CH19575 Under the condition of no data transmission, the tested module maintained for 10 minutes and recorded the average current for 10 minutes.	
			Band3 CH19250 Under the condition of no data transmission, the tested module maintained for 10 minutes and recorded the average current for 10 minutes.	
			Band3 CH19900 Under the condition of no data transmission, the tested module maintained for 10 minutes and recorded the average current for 10 minutes.	
			Band5 CH20600 Under the condition of no data transmission, the tested module maintained for 10 minutes and recorded the average current for 10 minutes.	

			<p>Band5 CH20450</p> <p>Under the condition of no data transmission, the tested module maintained for 10 minutes and recorded the average current for 10 minutes.</p>	
			<p>Band5 CH20525</p> <p>Under the condition of no data transmission, the tested module maintained for 10 minutes and recorded the average current for 10 minutes.</p>	
			<p>Band7 CH20800</p> <p>Under the condition of no data transmission, the tested module maintained for 10 minutes and recorded the average current for 10 minutes.</p>	
			<p>Band7 CH21100</p> <p>Under the condition of no data transmission, the tested module maintained for 10 minutes and recorded the average current for 10 minutes.</p>	
			<p>Band7 CH21400</p> <p>Under the condition of no data transmission, the tested module maintained for 10 minutes and recorded the average current for 10 minutes.</p>	
			<p>Band8 CH21750</p> <p>Under the condition of no data transmission, the tested module maintained for 10 minutes and recorded the average current for 10 minutes.</p>	
			<p>Band8 CH21625</p> <p>Under the condition of no data transmission, the tested module maintained for 10 minutes and recorded the average current for 10 minutes.</p>	
			<p>Band8 CH21500</p> <p>Under the condition of no data transmission, the tested module maintained for 10 minutes and recorded the average current for 10 minutes.</p>	

			<p>Band20 CH24200</p> <p>Under the condition of no data transmission, the tested module maintained for 10 minutes and recorded the average current for 10 minutes.</p>	
			<p>Band20 CH24300</p> <p>Under the condition of no data transmission, the tested module maintained for 10 minutes and recorded the average current for 10 minutes.</p>	
			<p>Band20 CH24400</p> <p>Under the condition of no data transmission, the tested module maintained for 10 minutes and recorded the average current for 10 minutes.</p>	
			<p>Band28A CH27260</p> <p>Under the condition of no data transmission, the tested module maintained for 10 minutes and recorded the average current for 10 minutes.</p>	
			<p>Band28A CH27310</p> <p>Under the condition of no data transmission, the tested module maintained for 10 minutes and recorded the average current for 10 minutes.</p>	
			<p>Band28A CH27359</p> <p>Under the condition of no data transmission, the tested module maintained for 10 minutes and recorded the average current for 10 minutes.</p>	
			<p>Band28B CH27460</p> <p>Under the condition of no data transmission, the tested module maintained for 10 minutes and recorded the average current for 10 minutes.</p>	
			<p>Band28B CH27535</p> <p>Under the condition of no data transmission, the tested module maintained for 10 minutes and recorded the average current for 10 minutes.</p>	

			<p>Band28B CH27609</p> <p>Under the condition of no data transmission, the tested module maintained for 10 minutes and recorded the average current for 10 minutes.</p>	
	Real network data sleep	Unicom /Mobile	Keep the data connection sending 256-byte packets back to the server every 5 minutes	
Data transmission	FDD	<p>1) Room temperature;</p> <p>2) Dc power supply is used to supply the module, and the voltage is set at 3.8V;</p>	<p>Band1 0dBm</p> <p>The tested module carries out data transmission and maintains for 5 minutes, and records the average current for 5 minutes</p>	
			<p>Band1 10dBm</p> <p>The tested module carries out data transmission and maintains for 5 minutes, and records the average current for 5 minutes</p>	
			<p>Band1 23dBm CH18300</p> <p>The tested module carries out data transmission and maintains for 5 minutes, and records the average current for 5 minutes</p>	
			<p>Band1 23dBm CH18050</p> <p>The tested module carries out data transmission and maintains for 5 minutes, and records the average current for 5 minutes</p>	
			<p>Band1 23dBm CH18550</p> <p>The tested module carries out data transmission and maintains for 5 minutes, and records the average current for 5 minutes</p>	
			<p>Band3 0dBm</p> <p>The tested module carries out data transmission and maintains for 5 minutes, and records the average current for 5 minutes</p>	

			<p>Band3 10dBm</p> <p>The tested module carries out data transmission and maintains for 5 minutes, and records the average current for 5 minutes</p>	
			<p>Band3 23dBm CH19575</p> <p>The tested module carries out data transmission and maintains for 5 minutes, and records the average current for 5 minutes</p>	
			<p>Band3 23dBm CH19250</p> <p>The tested module carries out data transmission and maintains for 5 minutes, and records the average current for 5 minutes</p>	
			<p>Band3 23dBm CH19900</p> <p>The tested module carries out data transmission and maintains for 5 minutes, and records the average current for 5 minutes</p>	
			<p>Band5 0dBm</p> <p>The tested module carries out data transmission and maintains for 5 minutes, and records the average current for 5 minutes</p>	
			<p>Band5 10dBm</p> <p>The tested module carries out data transmission and maintains for 5 minutes, and records the average current for 5 minutes</p>	
			<p>Band5 23dBm CH20525</p> <p>The tested module carries out data transmission and maintains for 5 minutes, and records the average current for 5 minutes</p>	
			<p>Band5 23dBm CH20450</p> <p>The tested module carries out data transmission and maintains for 5 minutes, and records the average current for 5 minutes</p>	

			<p>Band5 23dBm CH20600</p> <p>The tested module carries out data transmission and maintains for 5 minutes, and records the average current for 5 minutes</p>	
			<p>Band7 23dBm CH21100</p> <p>The tested module carries out data transmission and maintains for 5 minutes, and records the average current for 5 minutes</p>	
			<p>Band7 23dBm CH20800</p> <p>The tested module carries out data transmission and maintains for 5 minutes, and records the average current for 5 minutes</p>	
			<p>Band7 23dBm CH21400</p> <p>The tested module carries out data transmission and maintains for 5 minutes, and records the average current for 5 minutes</p>	
			<p>Band8 0dBm</p> <p>The tested module carries out data transmission and maintains for 5 minutes, and records the average current for 5 minutes</p>	
			<p>Band8 10dBm</p> <p>The tested module carries out data transmission and maintains for 5 minutes, and records the average current for 5 minutes</p>	
			<p>Band8 23dBm CH21625</p> <p>The tested module carries out data transmission and maintains for 5 minutes, and records the average current for 5 minutes</p>	
			<p>Band20 0dBm</p> <p>Middle channel tested module carries out data transmission and maintains for 5 minutes, and records the average current for 5 minutes</p>	

			<p>Band20 10dBm</p> <p>Middle channel tested module carries out data transmission and maintains for 5 minutes, and records the average current for 5 minutes</p>	
			<p>Band20 23dBm</p> <p>Low channel tested module carries out data transmission and maintains for 5 minutes, and records the average current for 5 minutes</p>	
			<p>Band20 23dBm</p> <p>Middle channel tested module carries out data transmission and maintains for 5 minutes, and records the average current for 5 minutes</p>	
			<p>Band20 23dBm</p> <p>Middle channel tested module carries out data transmission and maintains for 5 minutes, and records the average current for 5 minutes</p>	
			<p>Band28 0dBm CH21500</p> <p>Middle channel tested module carries out data transmission and maintains for 5 minutes, and records the average current for 5 minutes</p>	
			<p>Band28 10dBm CH21750</p> <p>Middle channel tested module carries out data transmission and maintains for 5 minutes, and records the average current for 5 minutes</p>	
			<p>Band28 23dBm</p> <p>Low channel tested module carries out data transmission and maintains for 5 minutes, and records the average current for 5 minutes</p>	
			<p>Band28 23dBm</p> <p>Middle channel tested module carries out data transmission and maintains for 5 minutes, and records the average current for 5 minutes</p>	

			<p>Band28 23dBm</p> <p>High channel tested module carries out data transmission and maintains for 5 minutes, and records the average current for 5 minutes</p>	
--	--	--	--	--

MeiG Confidential

6 Mechanical Characteristics

This section describes the mechanical dimensions of the module, all in millimeters; All dimensions not marked with tolerance, tolerance is $\pm 0.05\text{mm}$.

6.1 Module Dimension

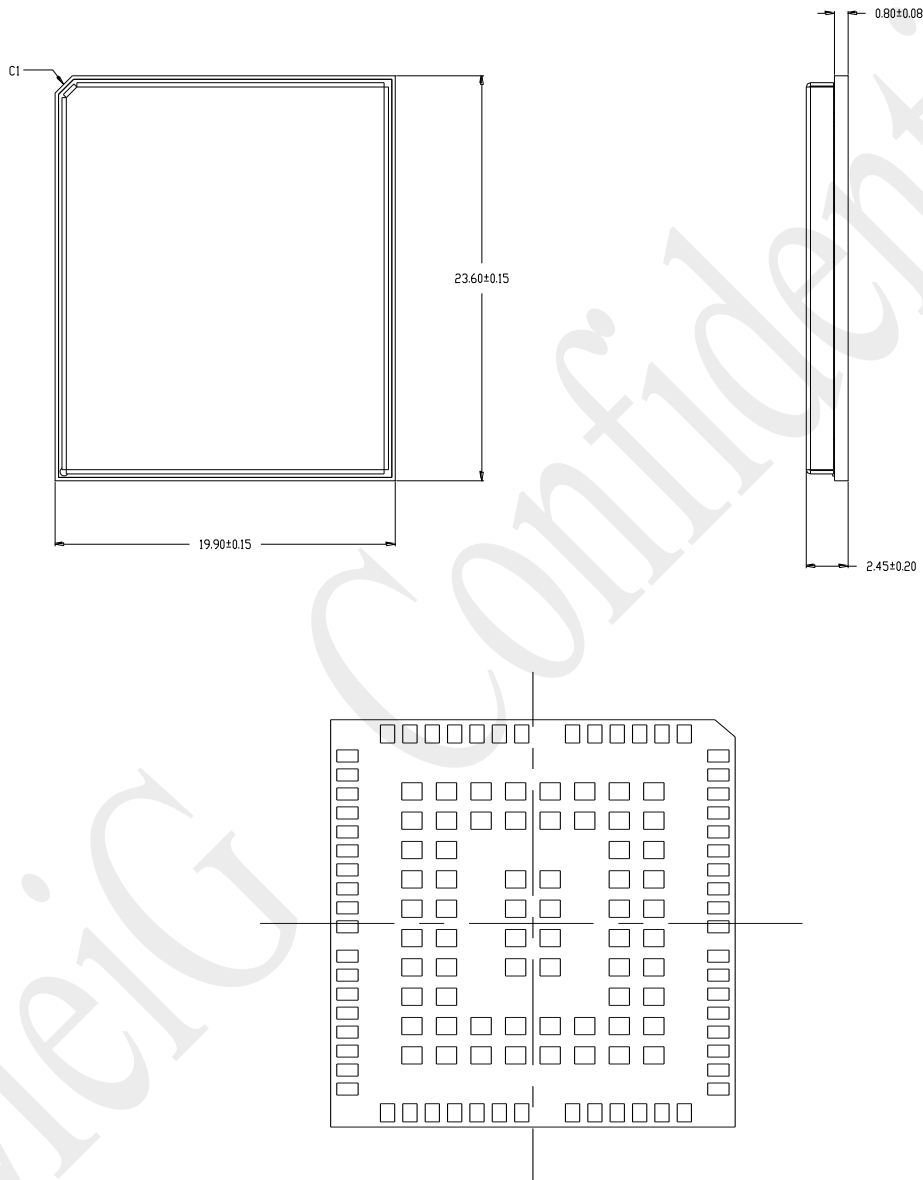

FIG. 23 Structural dimension drawing (unit: mm)

6.2 Recommended Package

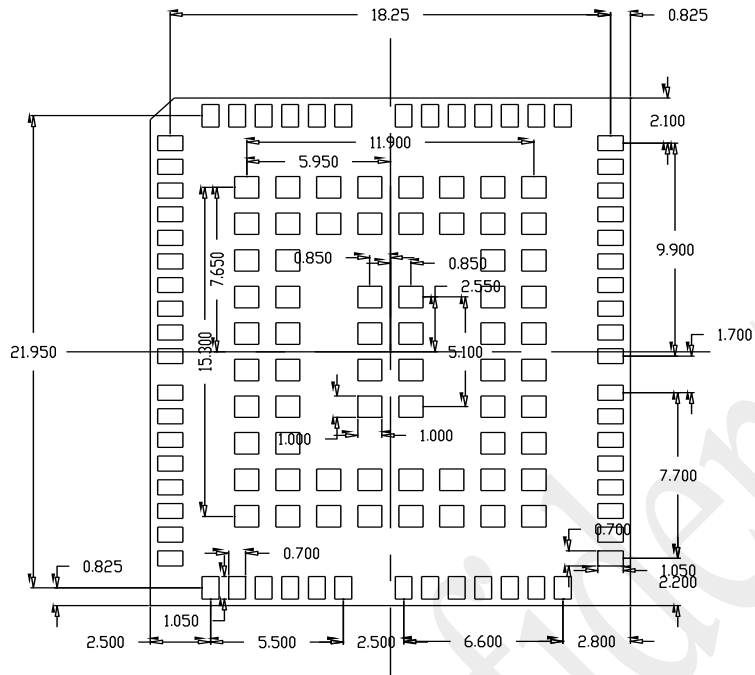

Figure 24 Recommended encapsulation (top view) (unit: mm)

6.3 Module Top View



Figure 25 Top view of the module

6.4 Module Bottom View

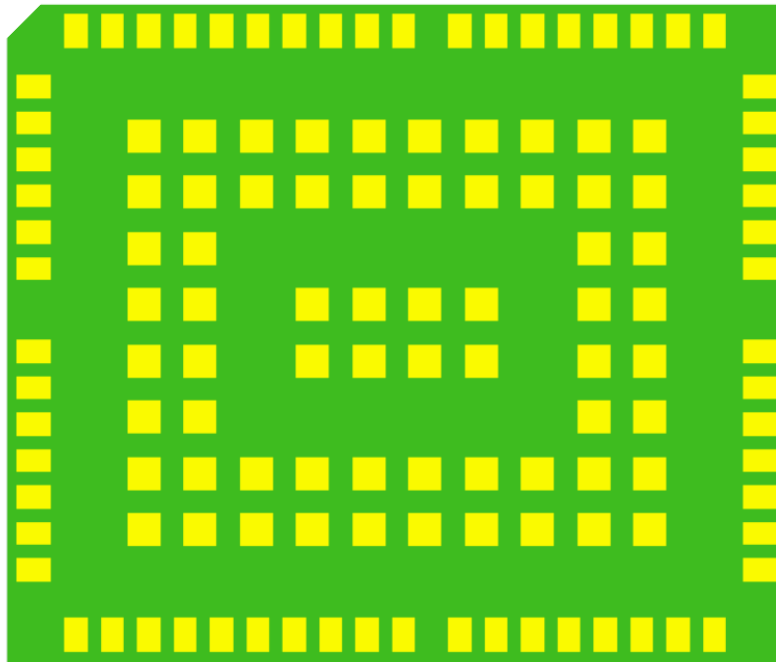

Figure 26. Bottom view of the module

7 Storage and Production

7.1 Storage

The SLM336 is shipped in vacuum sealed bags. The storage of modules shall be subject to the following conditions:

1. When the ambient temperature is lower than 40° C and the air humidity is less than 90%, the module can be stored in a vacuum sealed bag for 12 months;
2. After the vacuum seal bag is opened, the module can directly carry out reflow welding or other high-temperature processes if the following conditions are met:
 - The module stores air humidity less than 10%;
 - The environment temperature of module is lower than 30°C, the air humidity is less than 60%, the factory finishes the patch within 72 hours.
 - If the module is under the following conditions, it needs to be baked before the patch;
 - When the ambient temperature is 23°C (5°C fluctuation is allowed), the humidity indicator card shows a humidity level greater than 10%;
 - When the vacuum seal bag is opened, the ambient temperature of the module is lower than 30°C and the air humidity is less than 60%. However, the factory fails to complete the patch within 168 hours;
 - When the vacuum seal bag is opened, the module stores air humidity greater than 10%.
3. If the module needs to be baked, bake at 125°C (fluctuation of 5°C above and below) for 8 hours.

Remarks:

The module packaging cannot withstand such high temperature, please remove the module packaging before the module baking.

7.2 Manufacturing Welding

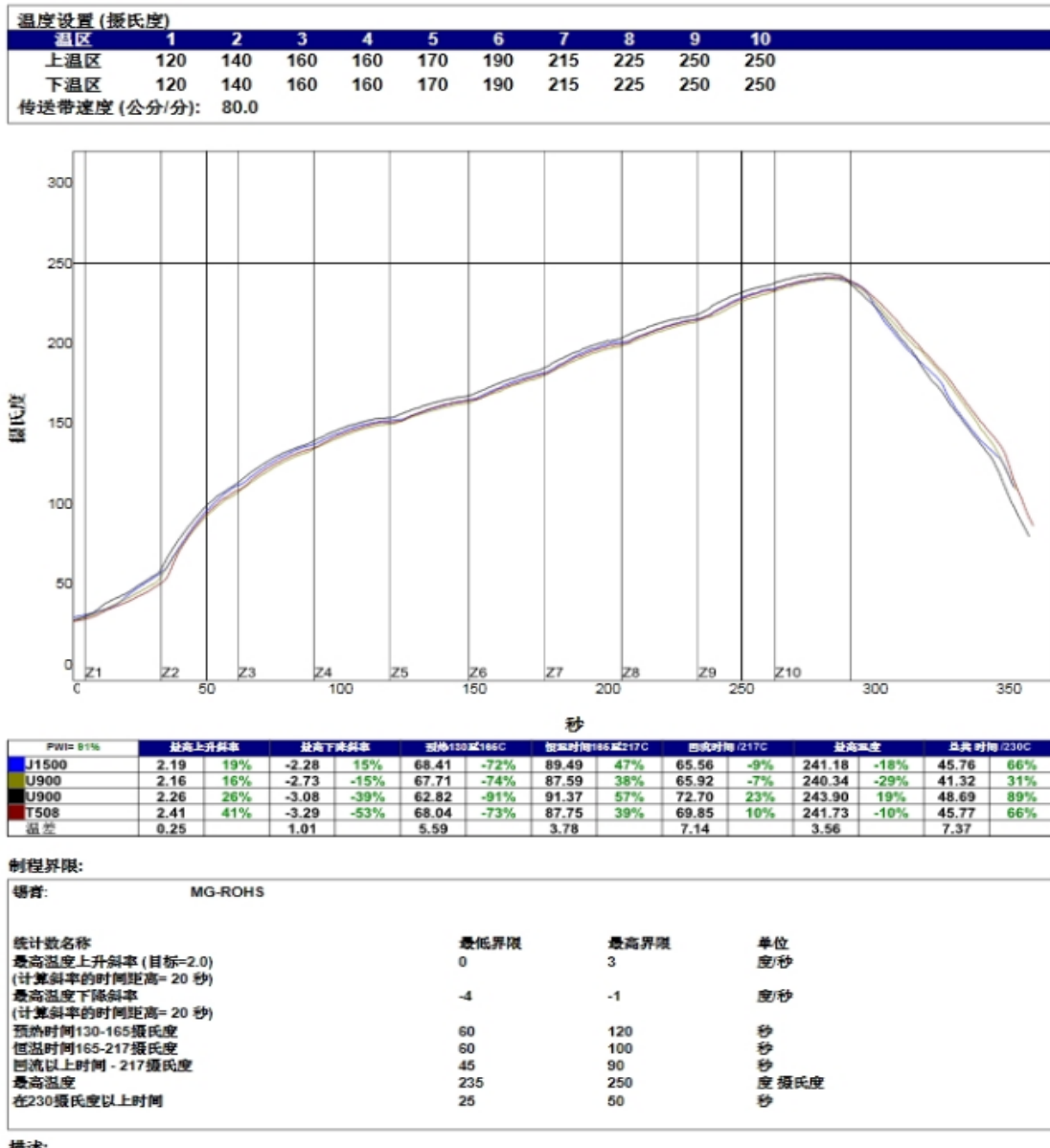

FIG. 27 Reflow temperature curve

8 Appendix A Reference and Term Abbreviation

8.1 Reference

- SLM336 Module specifications;
- SLM336 AT Commands;
- SLM336 EVB user's manual
- SLM336 Reference design circuit;
- SLM336 Apply the business process manual.

8.2 Term Abbreviation

Table 39 Term abbreviations

Abbreviation	English Description	Chinese Description
AMR	Adaptive Multi-rate	自适应多速率
BER	Bit Error Rate	误码率
BTS	Base Transceiver Station	基站收发信台
PCI	Peripheral Component Interconnect	外设部件互连
CS	Circuit Switched (CS) domain	电路域
CSD	Circuit Switched Data	电路交换数据
DCE	Data communication equipment	数据电路终端设备
DTE	Data terminal equipment	数据终端设备
DTR	Data Terminal Ready	数据终端就绪
EDGE	Enhanced Data rates for GSM Evolution	增强型GPRS
EFR	Enhanced Full Rate	增强型全速率
EGSM	Enhanced GSM	增强型GSM
EMC	Electromagnetic Compatibility	电磁兼容性
ESD	Electrostatic Discharge	静电释放
FR	Frame Relay	帧中继
GMSK	Gaussian Minimum Shift Keying	高斯最小移频键控
GPIO	General Purpose Input Output	通用输入/输出
GPRS	General Packet Radio Service	通用分组无线系统
GSM	Global Standard for Mobile Communications	全球标准移动通信系统
HR	Half Rate	半速
HSDPA	High Speed Downlink Packet Access	高速下行分组接入
HSUPA	High Speed Uplink Packet Access	高速上行分组接入
HSPA	HSPA High-Speed Packet Access	高速分组接入
HSPA+	HSPA High-Speed Packet Access+	增强型高速分组接入
IEC	International Electro-technical Commission	国际电工技术委员会

IMEI	International Mobile Equipment Identity	国际移动设备标识
MEID	Mobile Equipment Identifier	CDMA终端的身份识别码
I/O	Input/Output	输入/输出
ISO	International Standards Organization	国际标准化组织
ITU	International Telecommunications Union	国际电信联盟
bps	bits per second	比特每秒
LED	Light Emitting Diode	发光二极管
M2M	Machine to machine	机器到机器
MO	Mobile Originated	移动台发起的
MT	Mobile Terminated	移动台终止的
NTC	Negative Temperature Coefficient	负温度系数
PC	Personal Computer	个人计算机
PCB	Printed Circuit Board	印制电路板
PCS	Personal Cellular System	个人蜂窝系统
PCM	Pulse Code Modulation	脉冲编码调制
PCS	Personal Communication System	GSM1900
PDU	Packet Data Unit	分组数据单元
PPP	Point-to-point protocol	点到点协议
PS	Packet Switched	分组交换
QPSK	Quadrature Phase Shift Keying	正交相移频键控
SIM	Subscriber Identity Module	用户识别模组
TCP/IP	Transmission Control Protocol/ Internet Protocol	传输控制协议/互联网协议
UART	Universal asynchronous receiver-transmitter	通用异步收/发器（机）
USIM	Universal Subscriber Identity Module	通用用户识别模组
UMTS	Universal Mobile Telecommunications System	通用移动通信系统
USB	Universal Serial Bus	通用串行总线
WCDMA	Wideband Code Division Multiple Access	宽带码分多址
TD-SCDMA	Time Division-Synchronous Code Division Multiple Access	时分同步码分多址
TDD-LTE	Time Division Long Term Evolution	时分长期演进
FDD-LTE	Frequency Division Duplexing Long Term Evolution	频分长期演进
V _{max}	Maximum Voltage Value	最大电压值
V _{norm}	Normal Voltage Value	典型电压值
V _{min}	Minimum Voltage Value	最小电压值
V _{IHmax}	Maximum Input High Level Voltage Value	输入高电平的最大电压
V _{IHmin}	Minimum Input High Level Voltage Value	输入高电平的最小电压
V _{ILmax}	Maximum Input Low Level Voltage Value	输入低电平的最大电压
V _{ILmin}	Minimum Input Low Level Voltage Value	输入低电平的最小电压
V _{OHmax}	Maximum Output High Level Voltage Value	输出高电平的最大电压
V _{OHmin}	Minimum Output High Level Voltage Value	输出高电平的最小电压
V _{OLmax}	Maximum Output Low Level Voltage Value	输出低电平的最大电压
V _{OLmin}	Minimum Output Low Level Voltage Value	输出低电平的最小电压